

A
B

SECTION PG

POWER SUPPLY, GROUND & CIRCUIT ELEMENTS C

CONTENTS

<p>BASIC INSPECTION 2</p> <p>BATTERY 2</p> <p style="padding-left: 20px;">How to Handle Battery2</p> <p style="padding-left: 20px;">Work Flow2</p> <p>INSPECTION AND ADJUSTMENT 5</p> <p>ADDITIONAL SERVICE WHEN REMOVING BATTERY NEGATIVE TERMINAL5</p> <p style="padding-left: 20px;">ADDITIONAL SERVICE WHEN REMOVING BATTERY NEGATIVE TERMINAL : Special Repair Requirement5</p> <p>DTC/CIRCUIT DIAGNOSIS 6</p> <p>POWER SUPPLY ROUTING CIRCUIT 6</p> <p style="padding-left: 20px;">Wiring Diagram — Battery Power Supply —6</p> <p style="padding-left: 20px;">Wiring Diagram — Accessory Power Supply — 13</p> <p style="padding-left: 20px;">Wiring Diagram — Ignition Power Supply — 16</p> <p style="padding-left: 20px;">Fuse24</p> <p style="padding-left: 20px;">Fusible Link24</p> <p>GROUND25</p> <p style="padding-left: 20px;">Ground Distribution25</p> <p>HARNESS35</p> <p style="padding-left: 20px;">Harness Layout35</p> <p>ELECTRICAL UNITS LOCATION53</p> <p style="padding-left: 20px;">Electrical Units Location53</p> <p>HARNESS CONNECTOR57</p> <p style="padding-left: 20px;">Description57</p> <p>STANDARDIZED RELAY60</p> <p style="padding-left: 20px;">Description60</p>	<p>FUSE BLOCK - JUNCTION BOX (J/B)62</p> <p style="padding-left: 20px;">Terminal Arrangement62</p> <p>FUSE, FUSIBLE LINK AND RELAY BOX63</p> <p style="padding-left: 20px;">Terminal Arrangement63</p> <p>IPDM E/R (INTELLIGENT POWER DISTRIBUTION MODULE ENGINE ROOM)64</p> <p style="padding-left: 20px;">Fuse, Connector and Terminal Arrangement64</p> <p>PRECAUTION65</p> <p>PRECAUTIONS65</p> <p style="padding-left: 20px;">Precaution for Supplemental Restraint System (SRS) "AIR BAG" and "SEAT BELT PRE-TENSIONER"65</p> <p>PREPARATION66</p> <p>PREPARATION66</p> <p style="padding-left: 20px;">Special Service Tool66</p> <p style="padding-left: 20px;">Commercial Service Tool66</p> <p>REMOVAL AND INSTALLATION67</p> <p>BATTERY67</p> <p style="padding-left: 20px;">Exploded View67</p> <p style="padding-left: 20px;">Removal and Installation (Battery)67</p> <p style="padding-left: 20px;">Removal and Installation (Battery Tray)68</p> <p>SERVICE DATA AND SPECIFICATIONS (SDS)69</p> <p>BATTERY69</p> <p style="padding-left: 20px;">Battery69</p>	<p>D</p> <p>E</p> <p>F</p> <p>G</p> <p>H</p> <p>I</p> <p>J</p> <p>K</p> <p>L</p> <p>PG</p> <p>N</p> <p>O</p> <p>P</p>
---	---	--

BATTERY

< BASIC INSPECTION >

BASIC INSPECTION

BATTERY

How to Handle Battery

INFOID:000000009465137

CAUTION:

- If it becomes necessary to start the engine with a booster battery and jumper cables, use a 12-volt booster battery.
- After connecting battery cables, ensure that they are tightly clamped to battery terminals for good contact.
- Never add distilled water through the hole used to check specific gravity.

METHODS OF PREVENTING OVER-DISCHARGE

The following precautions must be taken to prevent over-discharging a battery.

- The battery surface (particularly its top) should always be kept clean and dry.
- The terminal connections should be clean and tight.
- At every routine maintenance, check the electrolyte level.
This also applies to batteries designated as "low maintenance" and "maintenance-free".

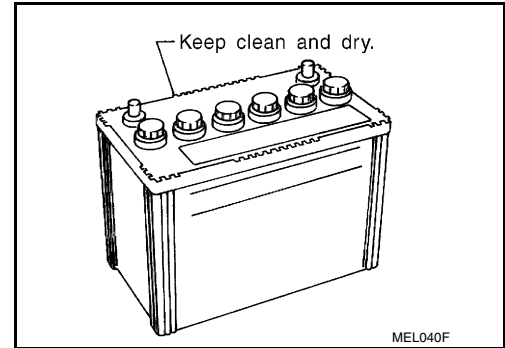

- When the vehicle is not going to be used over a long period of time, disconnect the battery cable from the negative terminal. (If the vehicle has an extended storage switch, turn it off.)

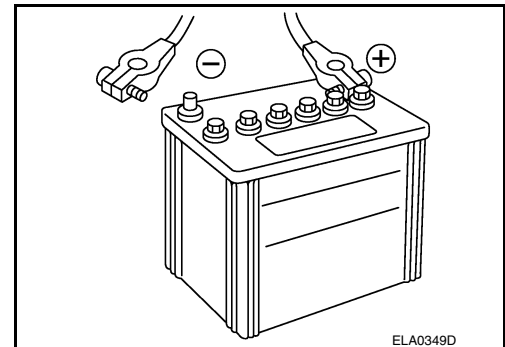

Work Flow

INFOID:000000009465138

BATTERY DIAGNOSIS WITH EXP-800 NI OR GR8-1200 NI

To diagnose and confirm the condition of the battery, use the following special service tools:

- EXP-800 NI Battery and electrical diagnostic analyzer
- GR8-1200 NI Multitasking battery and electrical diagnostic station

NOTE:

Refer to the applicable Instruction Manual for proper battery diagnosis procedures.

BATTERY DIAGNOSIS WITHOUT EXP-800 NI OR GR8-1200 NI

Checking Electrolyte Level

WARNING:

Never allow battery fluid to come in contact with skin, eyes, fabrics, or painted surfaces. After touching a battery, never touch or rub your eyes until you have thoroughly washed your hands. If acid contacts eyes, skin or clothing, immediately flush with water for 15 minutes and seek medical attention. Failure to do this may cause personal injury or damage to clothing or the painted surfaces.

BATTERY

< BASIC INSPECTION >

- Remove the cell plug using a suitable tool.
- Add distilled water up to the MAX level.

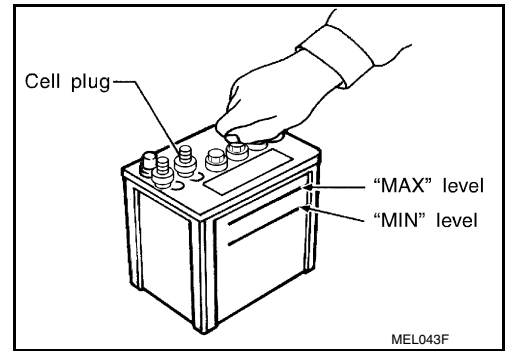

SULFATION

- **A battery will be completely discharged if it is left unattended for a long time and the specific gravity will become less than 1.100. This may result in sulfation on the cell plates.**
- **To determine if a battery has been “sulfated”, note its voltage and current when charging it. As shown in the figure, less current and higher voltage are observed in the initial stage of charging sulfated batteries.**
- **A sulfated battery may sometimes be brought back into service by means of a long, slow charge, 12 hours or more, followed by a battery capacity test.**

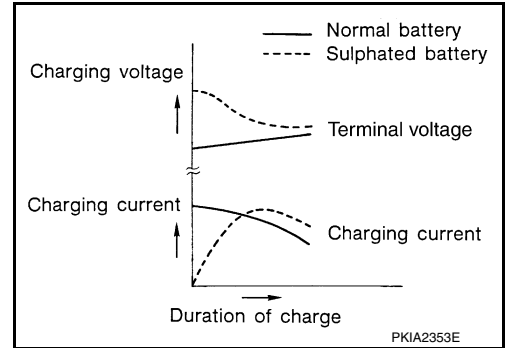

Specific Gravity Check

NOTE:

Check the charge condition of the battery.

Periodically check the specific gravity of the electrolyte. Keep a close check on charge condition to prevent over-discharge.

1. Read hydrometer and thermometer indications at eye level.
2. Use the chart below to correct your hydrometer reading according to electrolyte temperature.

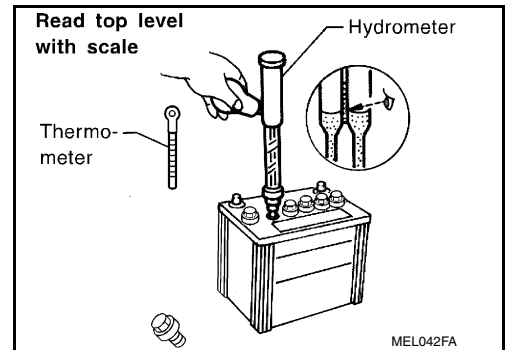

Hydrometer Temperature Correction

Battery electrolyte temperature [°C (°F)]	Add to specific gravity reading
71 (160)	0.032
66 (150)	0.028
60 (140)	0.024
54 (130)	0.020
49 (120)	0.016
43 (110)	0.012
38 (100)	0.008
32 (90)	0.004
27 (80)	0
21 (70)	-0.004
16 (60)	-0.008
10 (50)	-0.012

A
B
C
D
E
F
G
H
I
J
K
L
PG
N
O
P

BATTERY

< BASIC INSPECTION >

Battery electrolyte temperature [°C (°F)]	Add to specific gravity reading
4 (40)	-0.016
-1 (30)	-0.020
-7 (20)	-0.024
-12 (10)	-0.028
-18 (0)	-0.032

Corrected specific gravity	Approximate charge condition
1.260 - 1.280	Fully charged
1.230 - 1.250	3/4 charged
1.200 - 1.220	1/2 charged
1.170 - 1.190	1/4 charged
1.140 - 1.160	Almost discharged
1.110 - 1.130	Completely discharged

Charging The Battery

CAUTION:

- **Never “quick charge” a fully discharged battery.**
- **Keep the battery away from open flame while it is being charged.**
- **When connecting the charger, connect the leads first, then turn on the charger. Never turn on the charger first, as this may cause a spark.**
- **If battery electrolyte temperature rises above 55 °C (131 °F), stop charging. Always charge battery at a temperature below 55 °C (131 °F).**

Charging Rates (Standard Charge)

Approximate charge condition	Charge current (A)	Charge time (h)
Fully charged	7	2
3/4 charged		2.5
1/2 charged		5
1/4 charged		7.5
Almost discharged		9
Completely discharged		10

Charging Rates (Quick Charge)

Approximate charge condition	Charge current (A)	Charge time (h)
Fully charged	—	—
3/4 charged	16	0.5
1/2 charged	33	
1/4 charged		
Almost discharged	—	—
Completely discharged		

NOTE:

The ammeter reading on your battery charger will automatically decrease as the battery charges. This indicates that the voltage of the battery is increasing normally as the state of charge improves. The charging amps indicated above refer to initial charge rate.

- If, after charging, the specific gravity of any two cells varies more than 0.050, the battery should be replaced.

INSPECTION AND ADJUSTMENT

< BASIC INSPECTION >

INSPECTION AND ADJUSTMENT

ADDITIONAL SERVICE WHEN REMOVING BATTERY NEGATIVE TERMINAL

ADDITIONAL SERVICE WHEN REMOVING BATTERY NEGATIVE TERMINAL : Special Repair Requirement

INFOID:000000009465139

Required Procedure After Battery Disconnection

System	Item	Reference
Engine Control System	Idle Air Volume Learning	EC-19, "IDLE SPEED : Special Repair Requirement"
Power Window Control System	Power Window System Initialization	PWC-7, "ADDITIONAL SERVICE WHEN REMOVING BATTERY NEGATIVE TERMINAL : Special Repair Requirement"
Roof	Sunroof Memory Reset/Initialization	RF-7, "ADDITIONAL SERVICE WHEN REPLACING CONTROL UNIT : Special Repair Requirement" (Single Panel Sunroof) RF-76, "ADDITIONAL SERVICE WHEN REPLACING CONTROL UNIT : Special Repair Requirement" (Dual Panel Sunroof)
Automatic Drive Positioner	Automatic Drive Positioner System Initialization	Refer to Owner's Manual.
Heater & Air Conditioning Control System	Temperature Setting Trimmer	HAC-6, "Temperature Setting Trimmer" (Color Display) HAC-109, "Temperature Setting Trimmer" (Monochrome Display)
	Foot Position Setting Trimmer	HAC-7, "Foot Position Setting Trimmer" (Color Display) HAC-110, "Foot Position Setting Trimmer" (Monochrome Display)
	Inlet Port Memory Function (FRE)	HAC-7, "Inlet Port Memory Function (FRE)" (Color Display) HAC-110, "Inlet Port Memory Function (FRE)" (Monochrome Display)
	Inlet Port Memory Function (REC)	HAC-8, "Inlet Port Memory Function (REC)" (Color Display) HAC-111, "Inlet Port Memory Function (REC)" (Monochrome Display)
Audio, Visual & Navigation System	Audio (Radio Preset)	Refer to Owner's Manual.
	Navigation System	Refer to Owner's Manual.

A
B
C
D
E
F
G
H
I
J
K
L
N
O
P

PG

POWER SUPPLY ROUTING CIRCUIT

< DTC/CIRCUIT DIAGNOSIS >

DTC/CIRCUIT DIAGNOSIS

POWER SUPPLY ROUTING CIRCUIT

Wiring Diagram —Battery Power Supply —

INFOID:000000009465140

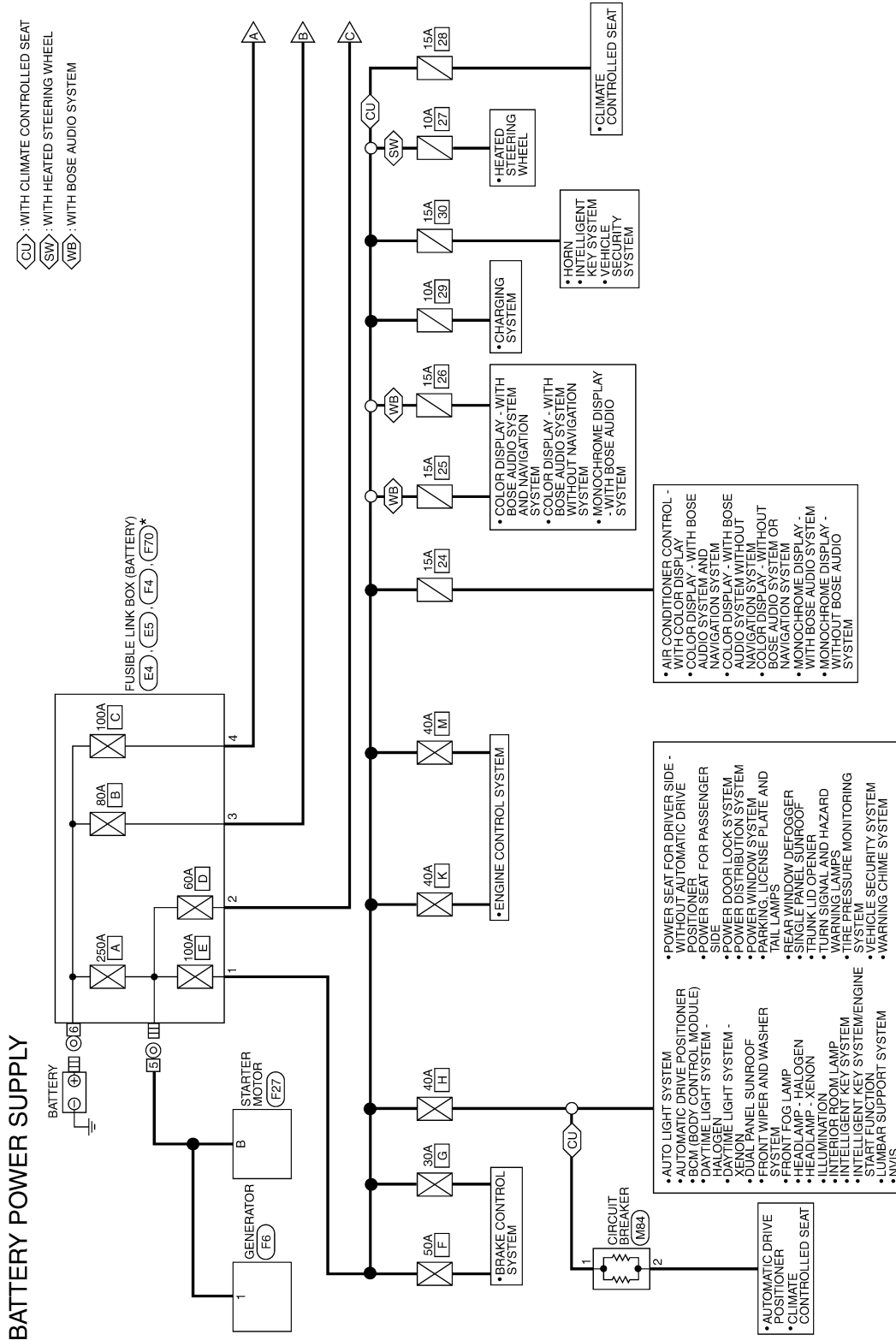

ABMWA2234GB

POWER SUPPLY ROUTING CIRCUIT

< DTC/CIRCUIT DIAGNOSIS >

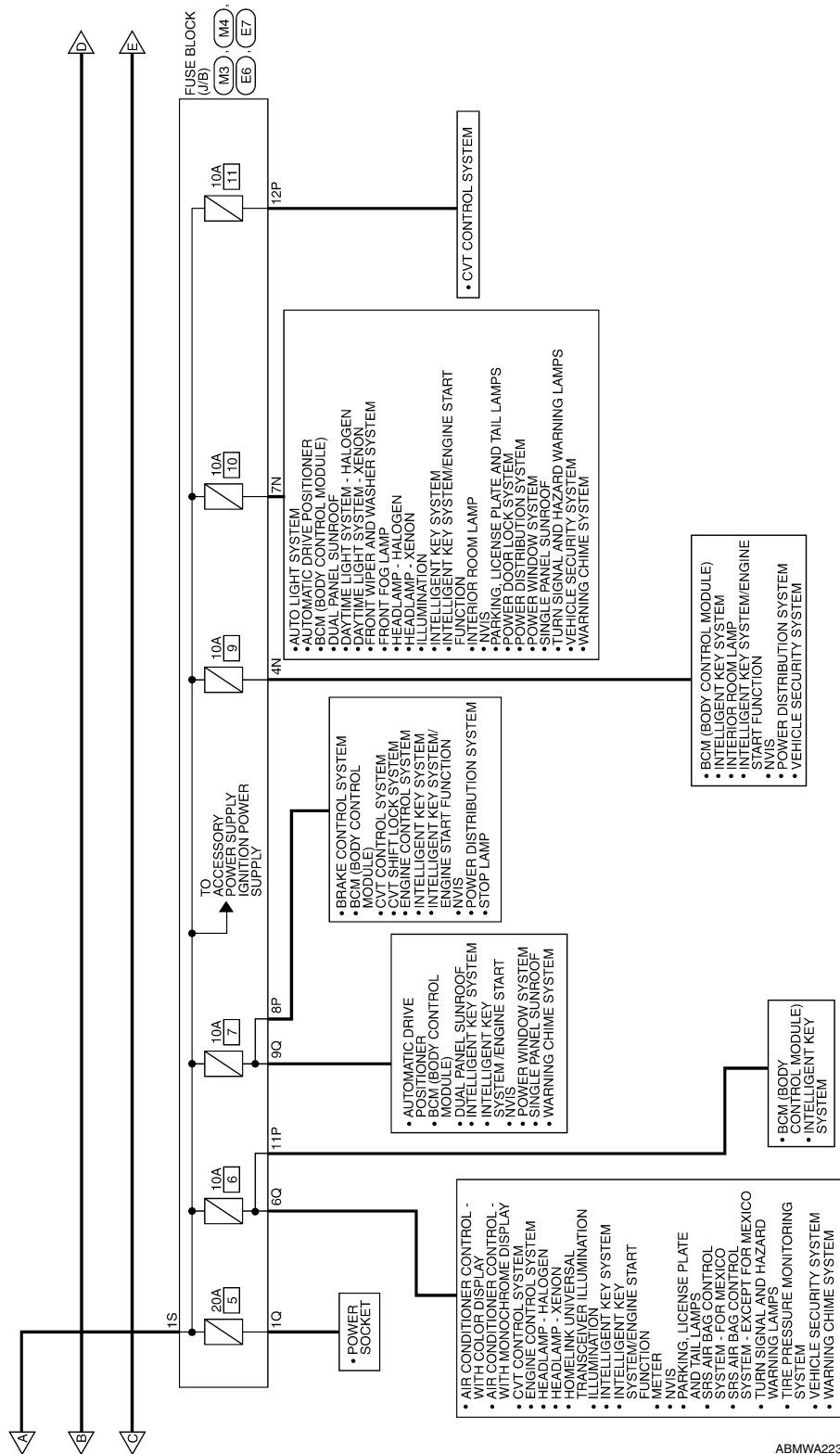

ABMWA2235GB

A
B
C
D
E
F
G
H
I
J
K
L
PG
N
O
P

POWER SUPPLY ROUTING CIRCUIT

< DTC/CIRCUIT DIAGNOSIS >

◻ FL ◻ : WITH FRONT FOG LAMPS

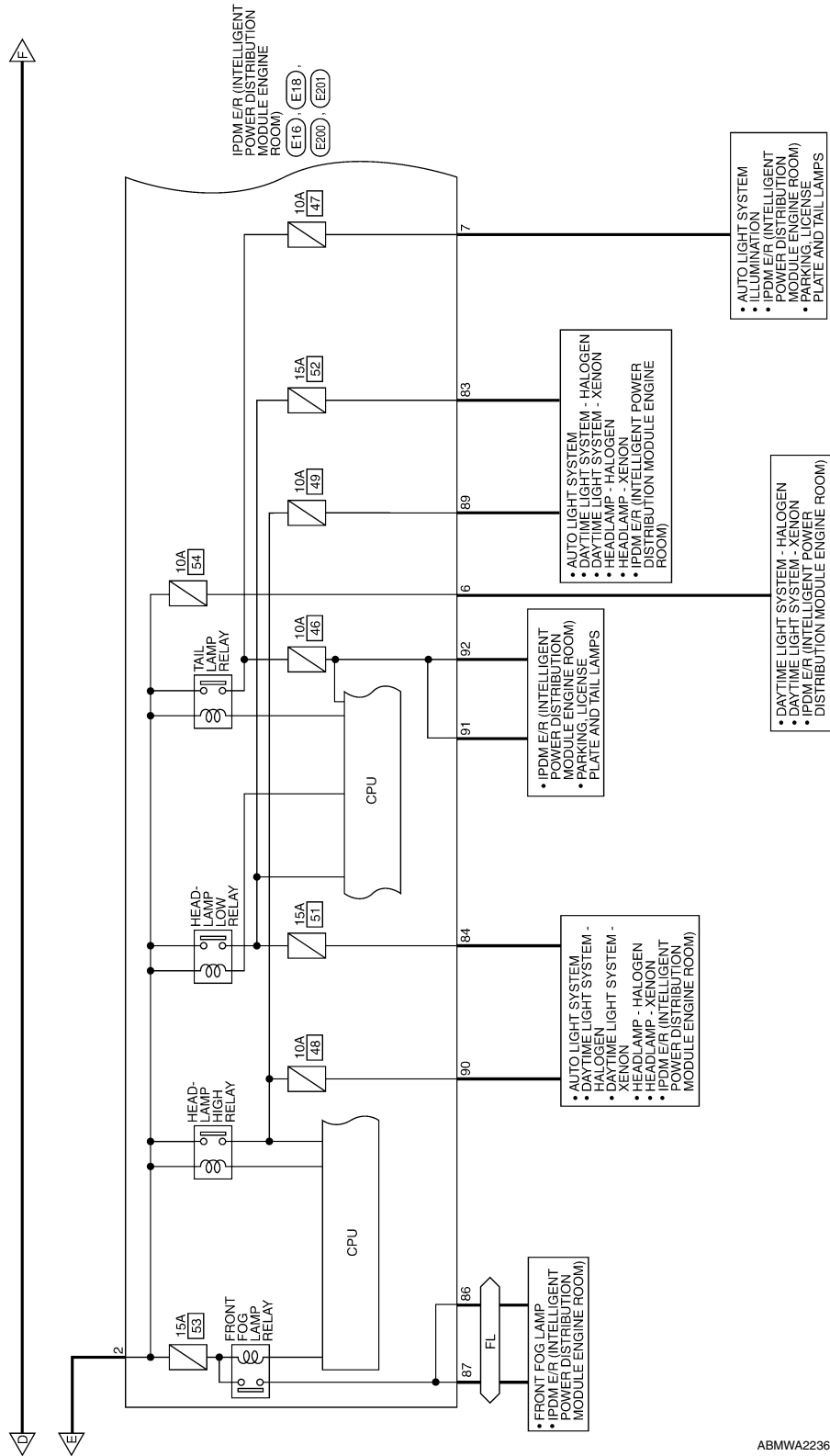

POWER SUPPLY ROUTING CIRCUIT

< DTC/CIRCUIT DIAGNOSIS >

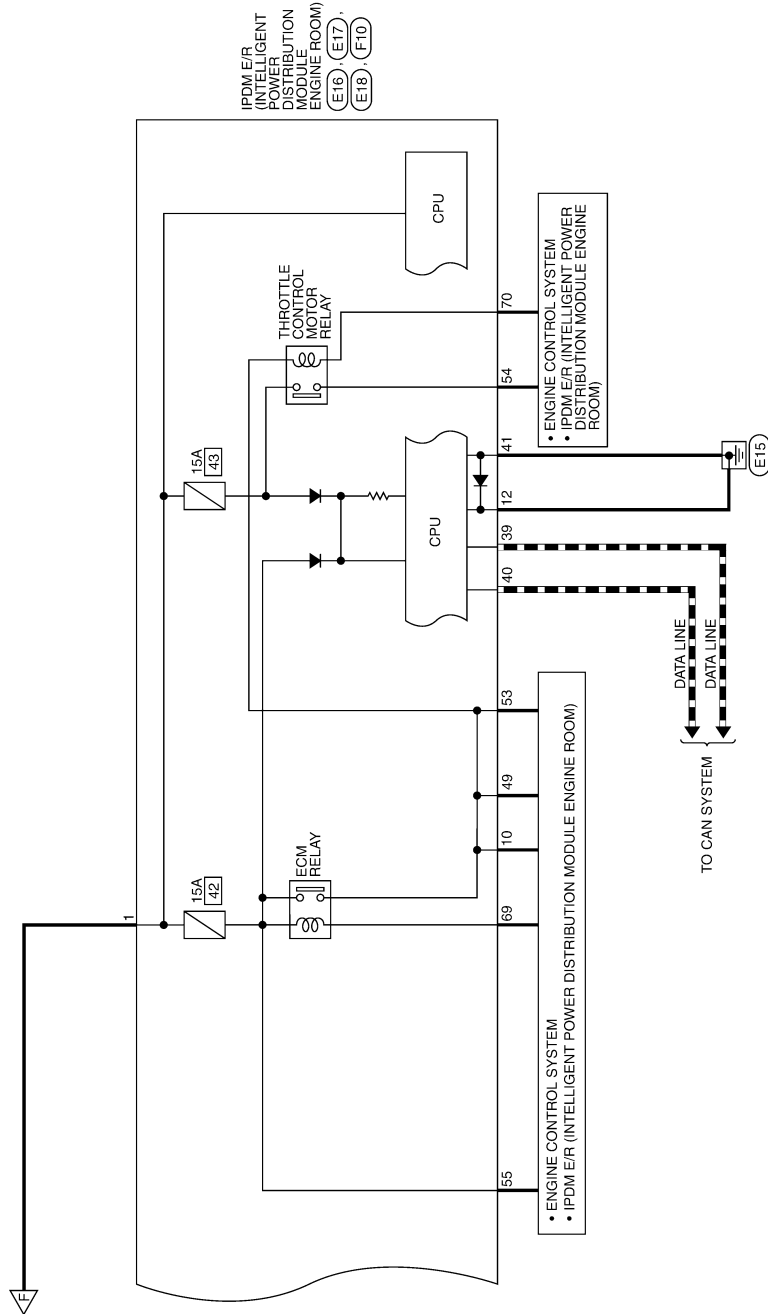

A
B
C
D
E
F
G
H
I
J
K
L
N
O
P

PG

ABMWA2237GB

POWER SUPPLY ROUTING CIRCUIT

< DTC/CIRCUIT DIAGNOSIS >

BATTERY POWER SUPPLY CONNECTORS

Connector No.	M3
Connector Name	FUSE BLOCK (J/B)
Connector Color	WHITE

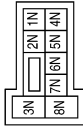

Terminal No.	Color of Wire	Signal Name
4N	G/Y	-
7N	Y/R	-

Connector No.	M4
Connector Name	FUSE BLOCK (J/B)
Connector Color	WHITE

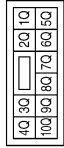

Terminal No.	Color of Wire	Signal Name
1Q	L	-
6Q	Y/R	-
9Q	R/W	-

Connector No.	M84
Connector Name	CIRCUIT BREAKER
Connector Color	WHITE



Terminal No.	Color of Wire	Signal Name
1	W/B	-
2	R/Y	-

Connector No.	E4
Connector Name	FUSIBLE LINK BOX (BATTERY)
Connector Color	BROWN



Terminal No.	Color of Wire	Signal Name
1	B/W	-
2	L	-

Connector No.	E5
Connector Name	FUSIBLE LINK BOX (BATTERY)
Connector Color	GRAY



Terminal No.	Color of Wire	Signal Name
3	R	-
4	W	-

Connector No.	E6
Connector Name	FUSE BLOCK (J/B)
Connector Color	WHITE



Terminal No.	Color of Wire	Signal Name
8P	R	-
11P	G	-
12P	V	-

POWER SUPPLY ROUTING CIRCUIT

< DTC/CIRCUIT DIAGNOSIS >

Connector No.	E17
Connector Name	IPDM E/R (INTELLIGENT POWER DISTRIBUTION MODULE ENGINE ROOM)
Connector Color	WHITE

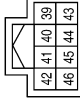

Terminal No.	Color of Wire	Signal Name
39	P	CAN-L
40	L	CAN-H
41	B	GND (SIGNAL)

Connector No.	E16
Connector Name	IPDM E/R (INTELLIGENT POWER DISTRIBUTION MODULE ENGINE ROOM)
Connector Color	BLACK



Terminal No.	Color of Wire	Signal Name
1	R	F/L MAIN
2	L	F/L USM

Connector No.	E7
Connector Name	FUSE BLOCK (J/B)
Connector Color	WHITE



Terminal No.	Color of Wire	Signal Name
1S	W	-

Connector No.	E200
Connector Name	IPDM E/R (INTELLIGENT POWER DISTRIBUTION MODULE ENGINE ROOM)
Connector Color	WHITE

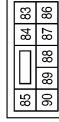

Terminal No.	Color of Wire	Signal Name
83	R/Y	HEADLAMP LO RH
84	L	HEADLAMP LO LH
86	W/R	FR FOG LAMP RH
87	L/Y	FR FOG LAMP LH
89	L/W	HEADLAMP HI RH
90	G	HEADLAMP HI LH

Terminal No.	Color of Wire	Signal Name
6	L	DTRL/DEICER
7	GR	TAIL/ILLUMI
10	BR	ECM VB
12	B	GND (POWER)

Connector No.	E18
Connector Name	IPDM E/R (INTELLIGENT POWER DISTRIBUTION MODULE ENGINE ROOM)
Connector Color	WHITE

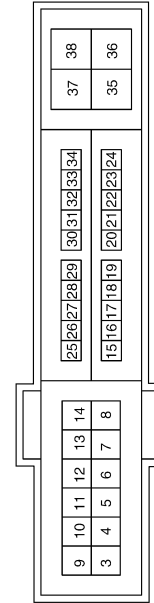

ABMIA2450GB

A
B
C
D
E
F
G
H
I
J
K
L
N
O
P

PG

POWER SUPPLY ROUTING CIRCUIT

< DTC/CIRCUIT DIAGNOSIS >

Connector No.	F6
Connector Name	GENERATOR
Connector Color	-



Terminal No.	Color of Wire	Signal Name
1	B/R	-

Connector No.	F4
Connector Name	FUSIBLE LINK BOX (BATTERY)
Connector Color	-



Terminal No.	Color of Wire	Signal Name
5	B/R	-

Connector No.	E201
Connector Name	IPDM E/R (INTELLIGENT POWER DISTRIBUTION MODULE ENGINE ROOM)
Connector Color	WHITE

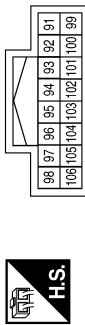

Terminal No.	Color of Wire	Signal Name
91	LG/R	CLEARANCE RH
92	LG/B	CLEARANCE LH

Connector No.	F27
Connector Name	STARTER MOTOR
Connector Color	-



Terminal No.	Color of Wire	Signal Name
B	B/R	-

Terminal No.	Color of Wire	Signal Name
49	R/B	IGN COIL
53	R/W	ENG SOL
54	G/W	ETC
55	W/L	ECM BAT
69	W/B	SSOFF
70	O	MOTRLY

Connector No.	F10
Connector Name	IPDM E/R (INTELLIGENT POWER DISTRIBUTION MODULE ENGINE ROOM)
Connector Color	WHITE

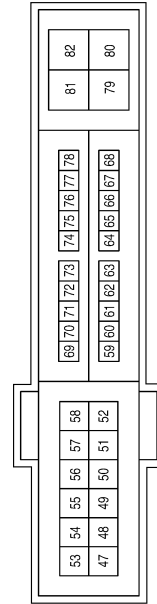

ABMIA5291GB

POWER SUPPLY ROUTING CIRCUIT

< DTC/CIRCUIT DIAGNOSIS >

Wiring Diagram —Accessory Power Supply—

INFOID:00000009465141

◻(OB) : WITHOUT BOSE AUDIO SYSTEM

ACCESSORY POWER SUPPLY

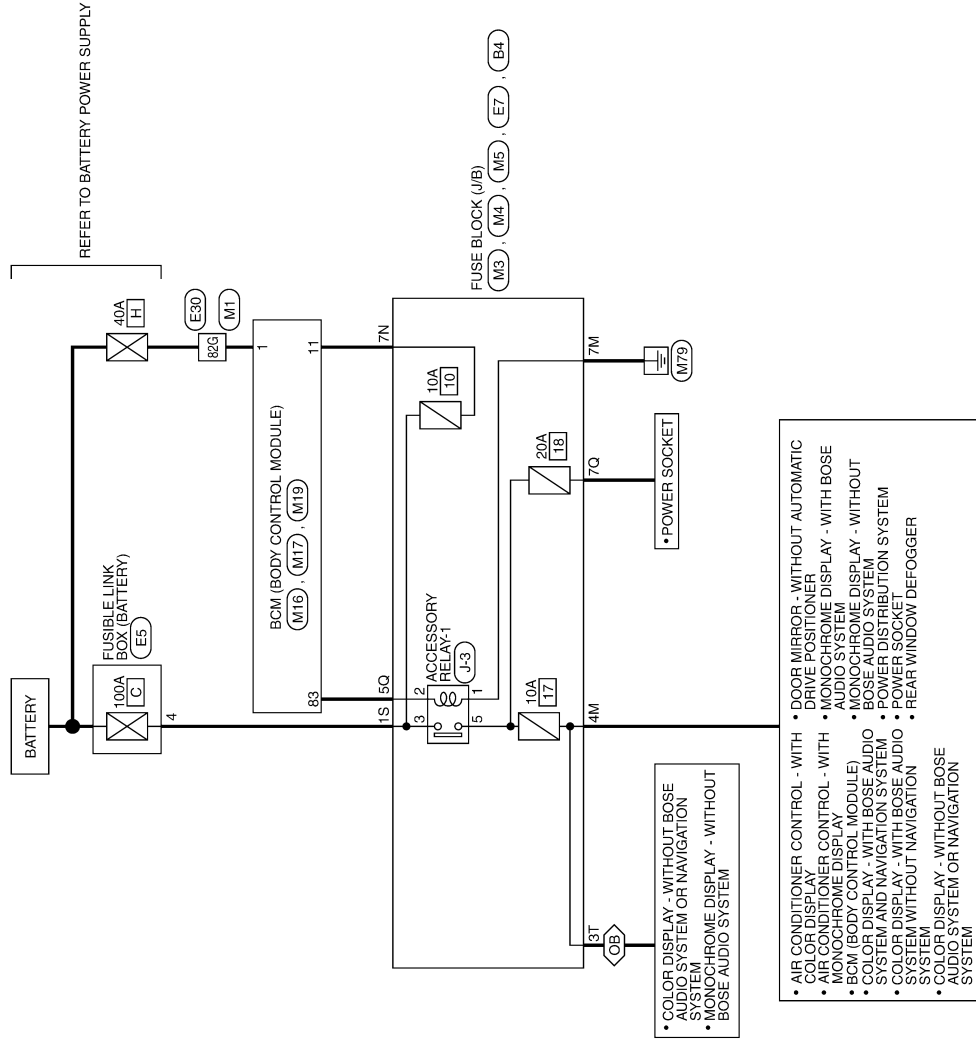

A
B
C
D
E
F
G
H
I
J
K
L

PG

N
O
P

ABMWA2238GB

POWER SUPPLY ROUTING CIRCUIT

< DTC/CIRCUIT DIAGNOSIS >

ACCESSORY POWER SUPPLY CONNECTORS

Connector No.	M1
Connector Name	WIRE TO WIRE
Connector Color	WHITE

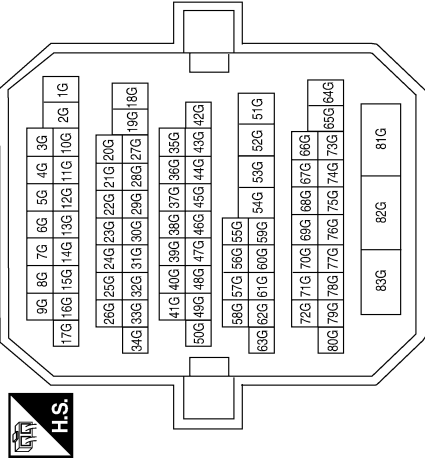

Terminal No.	Color of Wire	Signal Name
82G	W/B	-

Connector No.	M3
Connector Name	FUSE BLOCK (J/B)
Connector Color	WHITE

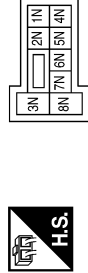

Terminal No.	Color of Wire	Signal Name
7N	Y/R	-

Connector No.	M4
Connector Name	FUSE BLOCK (J/B)
Connector Color	WHITE



Terminal No.	Color of Wire	Signal Name
5Q	L	-
7Q	R/B	-

Connector No.	M5
Connector Name	FUSE BLOCK (J/B)
Connector Color	WHITE

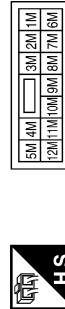

Terminal No.	Color of Wire	Signal Name
4M	V/Y	-
7M	B	-

Connector No.	M16
Connector Name	BCM (BODY CONTROL MODULE)
Connector Color	BLACK



Terminal No.	Color of Wire	Signal Name
1	W/B	BATT (F/L)

Connector No.	M17
Connector Name	BCM (BODY CONTROL MODULE)
Connector Color	WHITE

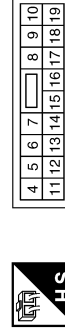

Terminal No.	Color of Wire	Signal Name
11	Y/R	BAT BCM FUSE

POWER SUPPLY ROUTING CIRCUIT

< DTC/CIRCUIT DIAGNOSIS >

Connector No.	E7
Connector Name	FUSE BLOCK (J/B)
Connector Color	WHITE



Terminal No.	Color of Wire	Signal Name
1S	W	-

Connector No.	E5
Connector Name	FUSIBLE LINK BOX (BATTERY)
Connector Color	GRAY



Terminal No.	Color of Wire	Signal Name
4	W	-

Connector No.	M19
Connector Name	BCM (BODY CONTROL MODULE)
Connector Color	BLACK

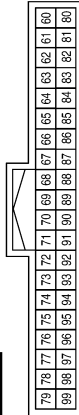

Terminal No.	Color of Wire	Signal Name
83	L	ACC CONT

Connector No.	J-3
Connector Name	FUSE BLOCK (J/B) (ACCESSORY RELAY-1)
Connector Color	-

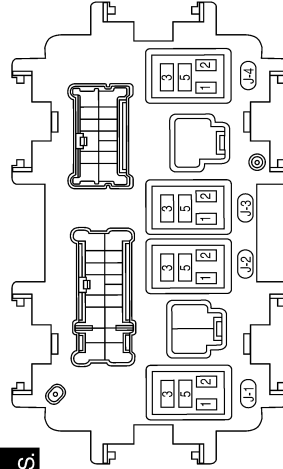

Connector No.	B4
Connector Name	FUSE BLOCK (J/B)
Connector Color	BROWN



Terminal No.	Color of Wire	Signal Name
3T	G	-

Connector No.	E30
Connector Name	WIRE TO WIRE
Connector Color	WHITE

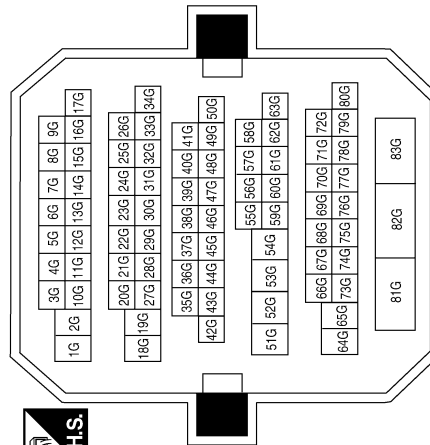

Terminal No.	Color of Wire	Signal Name
82G	LG	-

ABMIA5293GB

A
B
C
D
E
F
G
H
I
J
K
L
M
N
O
P

PG

POWER SUPPLY ROUTING CIRCUIT

< DTC/CIRCUIT DIAGNOSIS >

Wiring Diagram — Ignition Power Supply —

INFOID:000000009465142

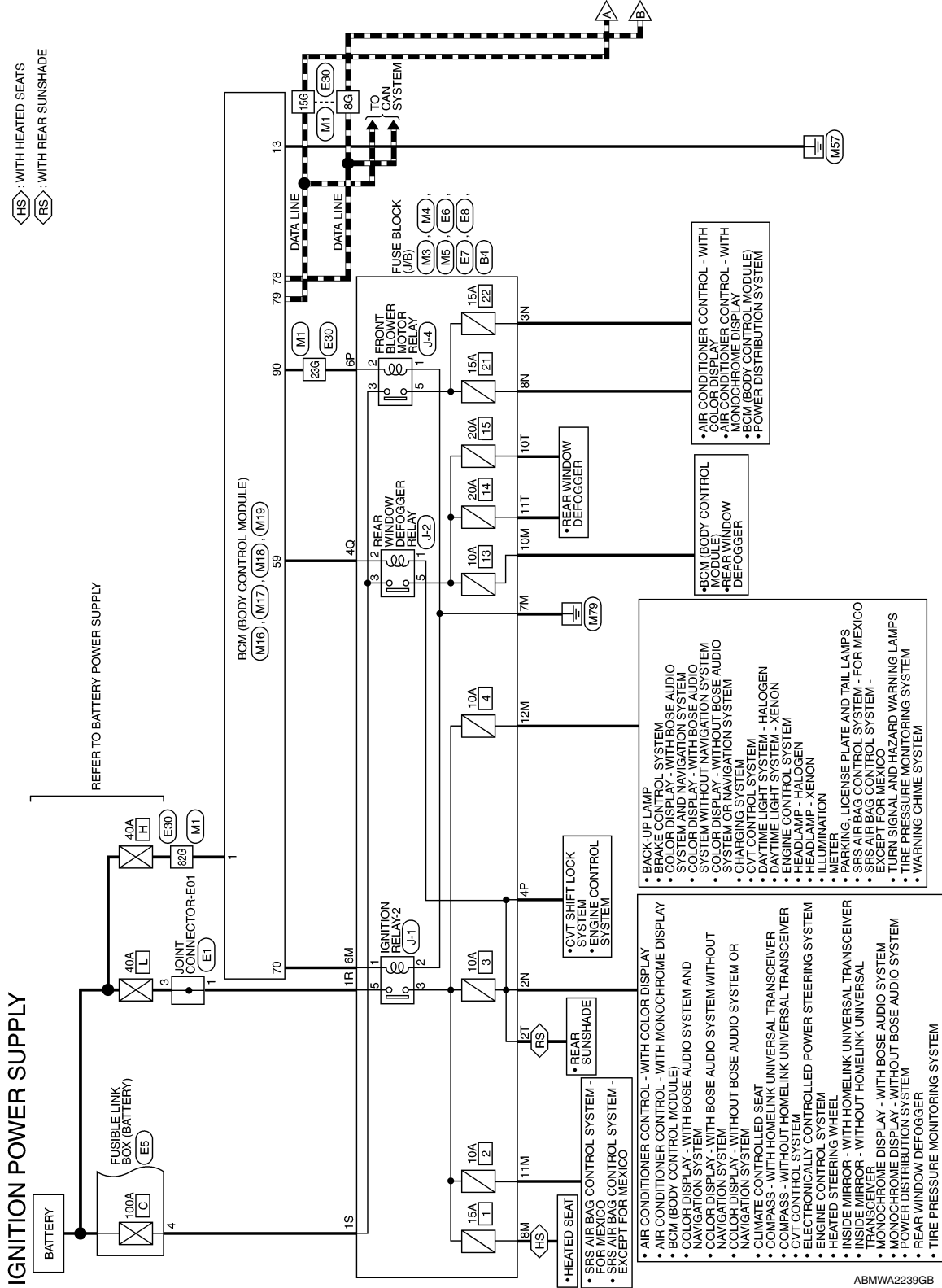

ABMWA2239GB

POWER SUPPLY ROUTING CIRCUIT

< DTC/CIRCUIT DIAGNOSIS >

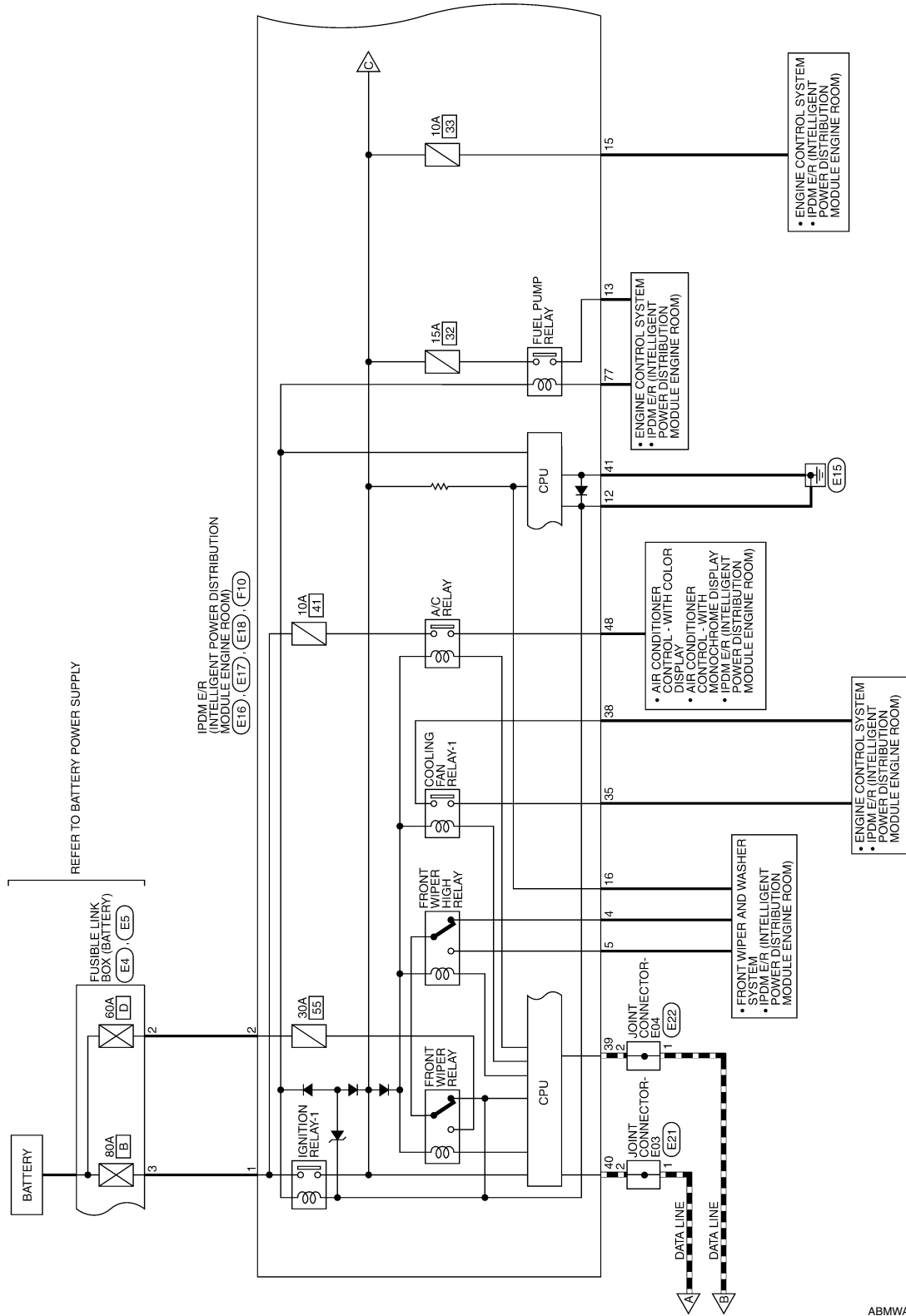

ABMWA2240GB

A
B
C
D
E
F
G
H
I
J
K
L
N
O
P

PG

POWER SUPPLY ROUTING CIRCUIT

< DTC/CIRCUIT DIAGNOSIS >

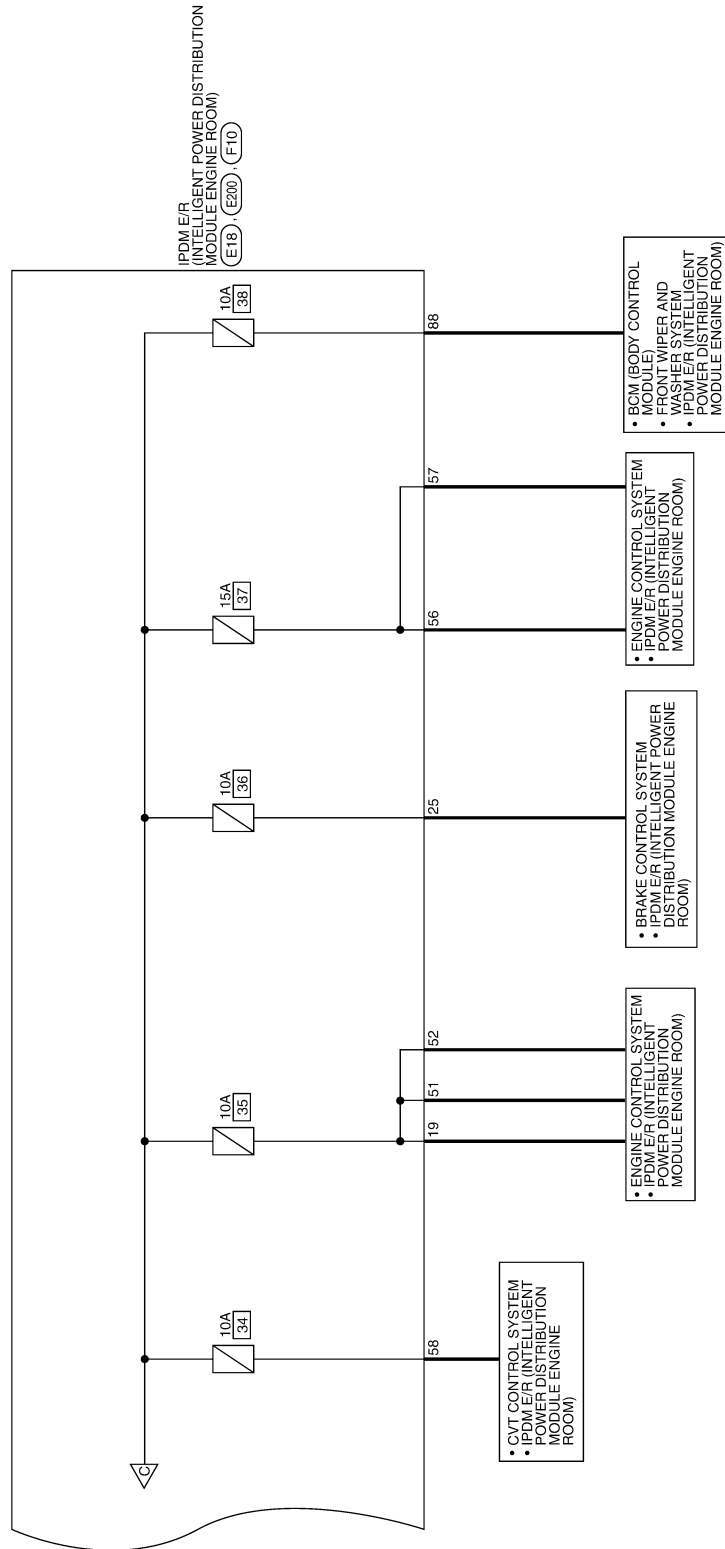

ABMWA2241GB

POWER SUPPLY ROUTING CIRCUIT

< DTC/CIRCUIT DIAGNOSIS >

IGNITION POWER SUPPLY CONNECTORS

Connector No.	M1
Connector Name	WIRE TO WIRE
Connector Color	WHITE

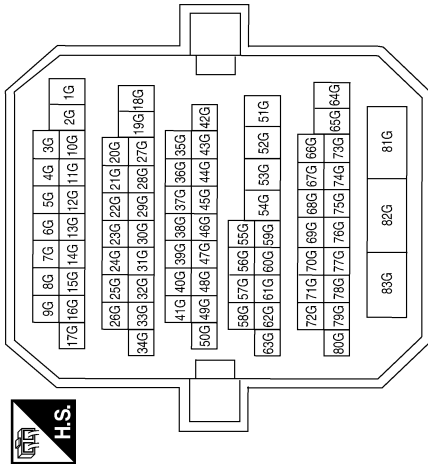

Terminal No.	Color of Wire	Signal Name
8G	P	-
15G	L	-
23G	Y	-
82G	W/B	-

Connector No.	M3
Connector Name	FUSE BLOCK (J/B)
Connector Color	WHITE

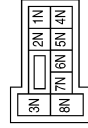

Terminal No.	Color of Wire	Signal Name
2N	G	-
3N	W/L	-
8N	W/L	-

Connector No.	M4
Connector Name	FUSE BLOCK (J/B)
Connector Color	WHITE

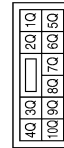

Terminal No.	Color of Wire	Signal Name
4Q	G/R	-

Connector No.	M5
Connector Name	FUSE BLOCK (J/B)
Connector Color	WHITE

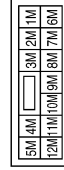

Terminal No.	Color of Wire	Signal Name
6M	R/B	-
7M	B	-
8M	G/R	-
10M	O	-
11M	R/L	-
12M	O	-

Connector No.	M16
Connector Name	BCM (BODY CONTROL MODULE)
Connector Color	BLACK



Terminal No.	Color of Wire	Signal Name
1	W/B	BATT (F/L)

ABMIA2481GB

A
B
C
D
E
F
G
H
I
J
K
L
M
N
O
P

POWER SUPPLY ROUTING CIRCUIT

< DTC/CIRCUIT DIAGNOSIS >

Connector No.	M19
Connector Name	BCM (BODY CONTROL MODULE)
Connector Color	BLACK

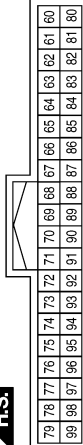
79	78	77	76	75	74	73	72	71	70	69	68	67	66	65	64	63	62	61	60
99	98	97	96	95	94	93	92	91	90	89	88	87	86	85	84	83	82	81	80

Terminal No.	Color of Wire	Signal Name
70	R/B	IGN REL OUTPUT2
78	P	CAN-L
79	L	CAN-H
90	Y	BLOWER FAN RELAY

Connector No.	M18
Connector Name	BCM (BODY CONTROL MODULE)
Connector Color	GREEN

39	38	37	36	35	34	33	32	31	30	29	28	27	26	25	24	23	22	21	20
59	58	57	56	55	54	53	52	51	50	49	48	47	46	45	44	43	42	41	40

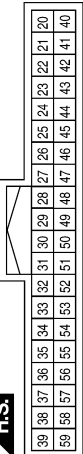
Terminal No.	Color of Wire	Signal Name
59	G/R	REAR DEFOGGER

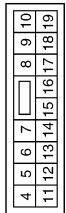

Connector No.	M17
Connector Name	BCM (BODY CONTROL MODULE)
Connector Color	WHITE

4	5	6	7	8	9	10		
11	12	13	14	15	16	17	18	19



Terminal No.	Color of Wire	Signal Name
13	B	GND1

Connector No.	E5
Connector Name	FUSIBLE LINK BOX (BATTERY)
Connector Color	GRAY



Terminal No.	Color of Wire	Signal Name
3	R	-
4	W	-

Connector No.	E4
Connector Name	FUSIBLE LINK BOX (BATTERY)
Connector Color	BROWN

Terminal No.	Color of Wire	Signal Name
2	L	-

Connector No.	E1
Connector Name	JOINT CONNECTOR-E01
Connector Color	WHITE

Terminal No.	Color of Wire	Signal Name
1	G	-
3	G	-

ABMIA0862GB

POWER SUPPLY ROUTING CIRCUIT

< DTC/CIRCUIT DIAGNOSIS >

Connector No.	E8
Connector Name	FUSE BLOCK (J/B)
Connector Color	BLACK



Terminal No.	Color of Wire	Signal Name
1R	G	-

Connector No.	E7
Connector Name	FUSE BLOCK (J/B)
Connector Color	WHITE



Terminal No.	Color of Wire	Signal Name
1S	W	-

Connector No.	E6
Connector Name	FUSE BLOCK (J/B)
Connector Color	WHITE

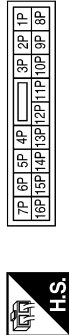

Terminal No.	Color of Wire	Signal Name
4P	P	-
6P	Y	-

Connector No.	E18
Connector Name	IPDM E/R (INTELLIGENT POWER DISTRIBUTION MODULE ENGINE ROOM)
Connector Color	WHITE



Terminal No.	Color of Wire	Signal Name
4	LG	FR WIPER LO
5	Y	FR WIPER HI
12	B	GND (POWER)
13	SB	FUEL PUMP
15	W	START IG E/R
16	R	WIPER AUTOSTOP
19	Y	BCM IGNSW
25	GR	ABS ECU
35	P	MOTOR FAN LO
38	GR	F/L MOTOR FAN

Connector No.	E17
Connector Name	IPDM E/R (INTELLIGENT POWER DISTRIBUTION MODULE ENGINE ROOM)
Connector Color	WHITE



Terminal No.	Color of Wire	Signal Name
39	P	CAN-L
40	L	CAN-H
41	B	GND (SIGNAL)

Connector No.	E16
Connector Name	IPDM E/R (INTELLIGENT POWER DISTRIBUTION MODULE ENGINE ROOM)
Connector Color	BLACK



Terminal No.	Color of Wire	Signal Name
1	R	F/L MAIN
2	L	F/L USM

ABMIA5294GB

A
B
C
D
E
F
G
H
I
J
K
L
M
N
O
P

POWER SUPPLY ROUTING CIRCUIT

< DTC/CIRCUIT DIAGNOSIS >

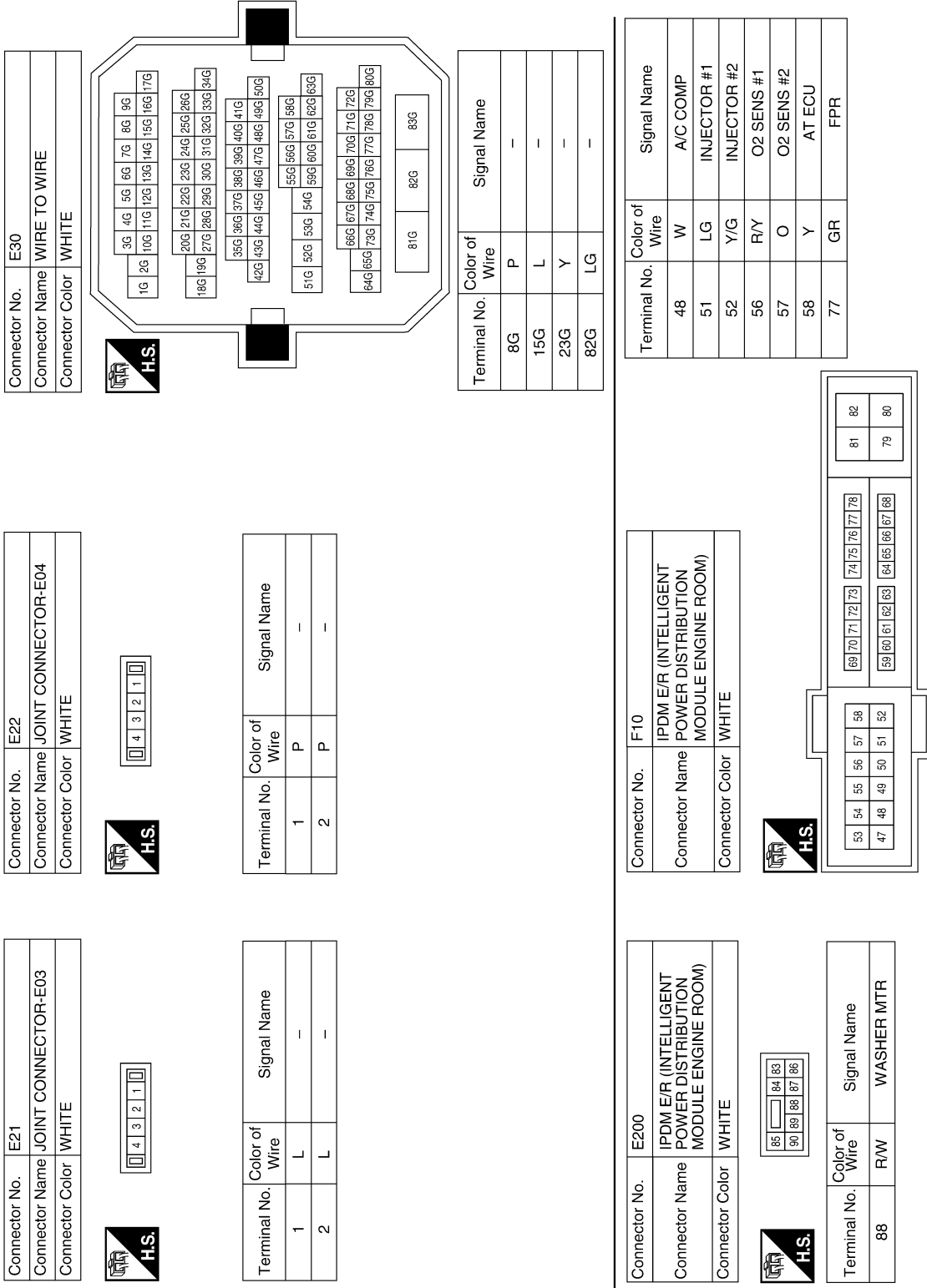

Connector No.	E30
Connector Name	WIRE TO WIRE
Connector Color	WHITE

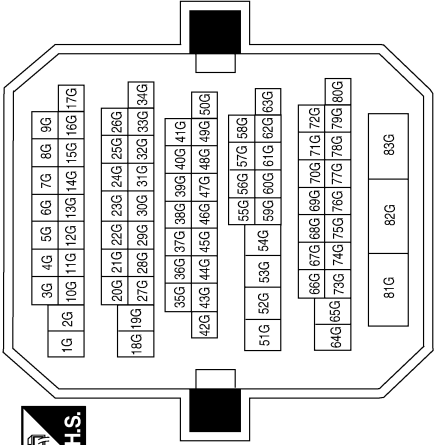

Terminal No.	Color of Wire	Signal Name
8G	P	-
15G	L	-
23G	Y	-
82G	LG	-

Terminal No.	Color of Wire	Signal Name
48	W	A/C COMP
51	LG	INJECTOR #1
52	Y/G	INJECTOR #2
56	R/Y	O2 SENS #1
57	O	O2 SENS #2
58	Y	AT ECU
77	GR	FPR

Connector No.	E22
Connector Name	JOINT CONNECTOR-E04
Connector Color	WHITE



Terminal No.	Color of Wire	Signal Name
1	P	-
2	P	-

Connector No.	F10
Connector Name	IPDM E/R (INTELLIGENT POWER DISTRIBUTION MODULE ENGINE ROOM)
Connector Color	WHITE

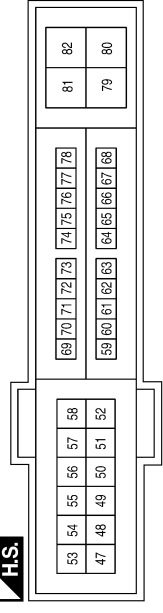

Connector No.	E21
Connector Name	JOINT CONNECTOR-E03
Connector Color	WHITE



Terminal No.	Color of Wire	Signal Name
1	L	-
2	L	-

Connector No.	E200
Connector Name	IPDM E/R (INTELLIGENT POWER DISTRIBUTION MODULE ENGINE ROOM)
Connector Color	WHITE

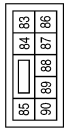

Terminal No.	Color of Wire	Signal Name
88	R/W	WASHER MTR

ABMIA0275GB

POWER SUPPLY ROUTING CIRCUIT

< DTC/CIRCUIT DIAGNOSIS >

Connector No.	J-2
Connector Name	FUSE BLOCK (J/B) (REAR WINDOW DEFOGGER RELAY)
Connector Color	-

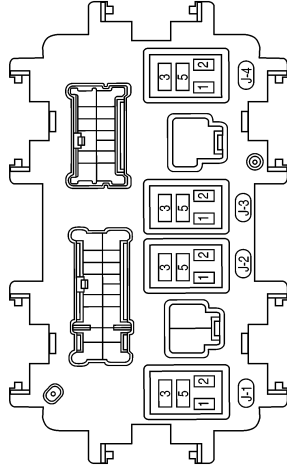

Connector No.	J-1
Connector Name	FUSE BLOCK (J/B) (IGNITION RELAY-2)
Connector Color	-

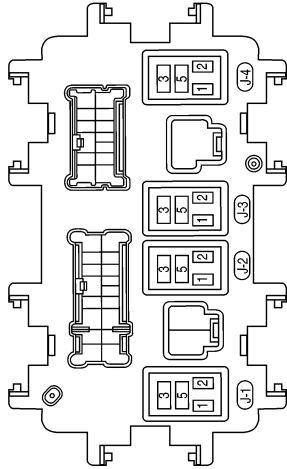

Connector No.	B4
Connector Name	FUSE BLOCK (J/B)
Connector Color	BROWN

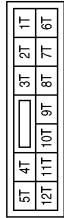

Terminal No.	Color of Wire	Signal Name
2T	V	-
10T	Y	-
11T	Y	-

Connector No.	J-4
Connector Name	FUSE BLOCK (J/B) (FRONT BLOWER MOTOR RELAY)
Connector Color	-

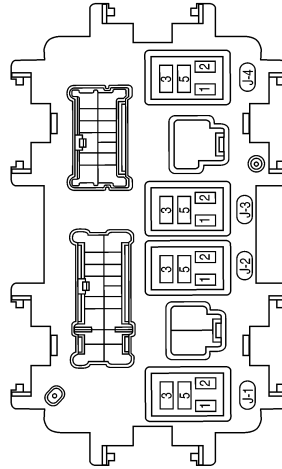

A
B
C
D
E
F
G
H
I
J
K
L
PG
N
O
P

POWER SUPPLY ROUTING CIRCUIT

< DTC/CIRCUIT DIAGNOSIS >

Fuse

INFOID:000000009465143

- If fuse is blown, be sure to eliminate cause of malfunction before installing new fuse.
- Use fuse of specified rating. Never use fuse of more than specified rating.
- Do not partially install fuse; always insert it into fuse holder properly.
- Remove fuse for "ELECTRICAL PARTS (BAT)" if vehicle is not used for a long period of time.

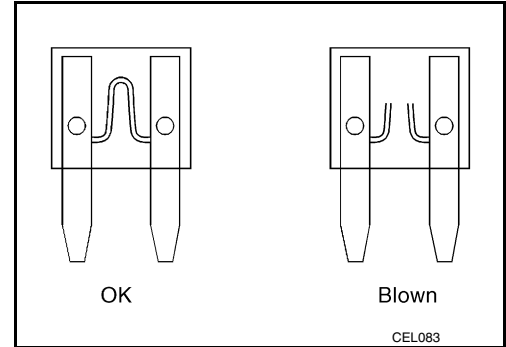

Fusible Link

INFOID:000000009465144

A melted fusible link can be detected either by visual inspection or by feeling with finger tip. If its condition is questionable, use circuit tester or test lamp.

1 : Fusible link

CAUTION:

- If fusible link should melt, it is possible that critical circuit (power supply or large current carrying circuit) is shorted. In such a case, carefully check and eliminate cause of malfunction.
- Never wrap outside of fusible link with vinyl tape. Important: Never let fusible link touch any other wiring harness, vinyl or rubber parts.

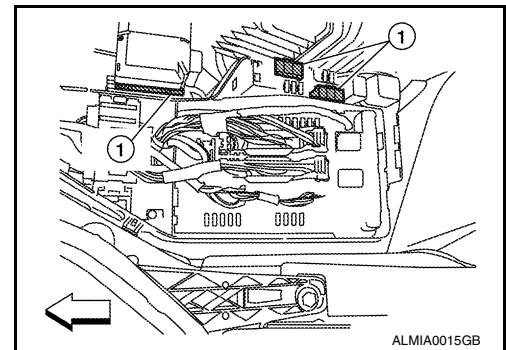

GROUND

< DTC/CIRCUIT DIAGNOSIS >

GROUND

Ground Distribution

INFOID:000000009465145

MAIN HARNESS

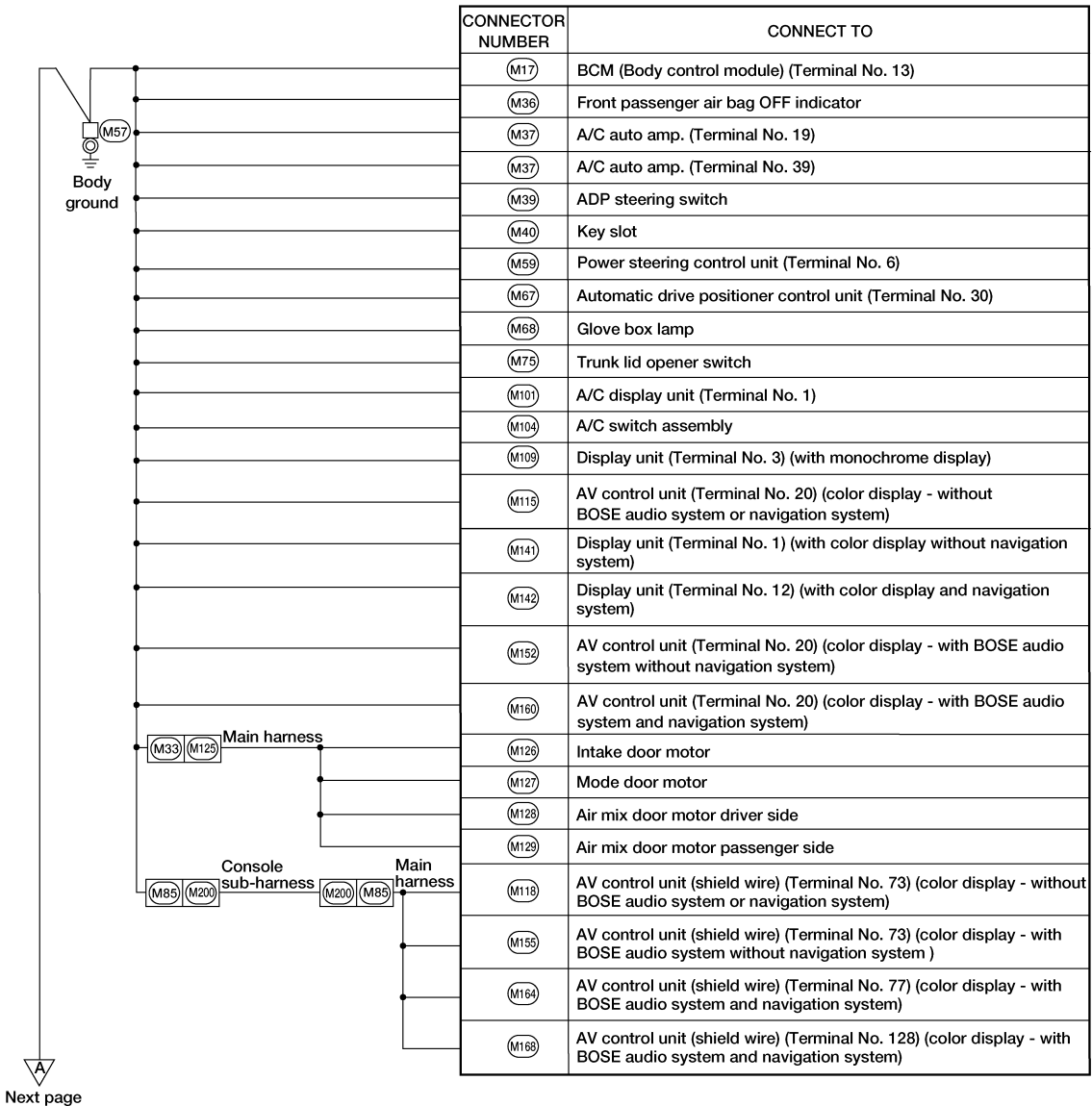
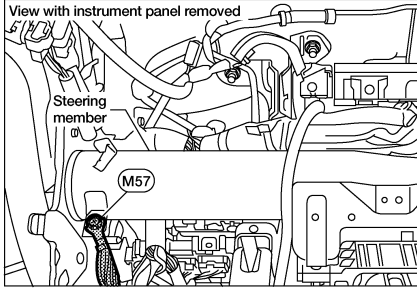

Next page

A
B
C
D
E
F
G
H
I
J
K
L
PG
N
O
P

GROUND

< DTC/CIRCUIT DIAGNOSIS >

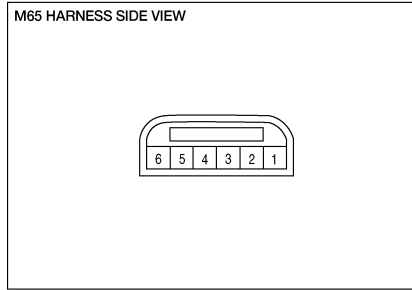
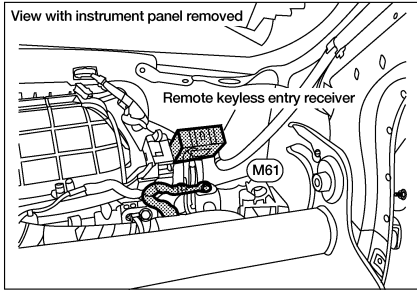

Preceding page

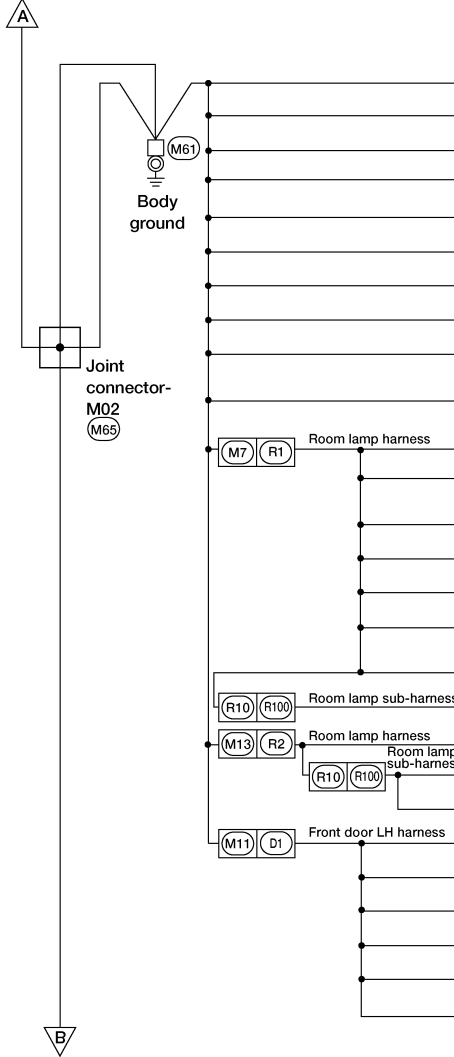

Next page

CONNECTOR NUMBER	CONNECT TO
(M22)	Data link connector (Terminal No. 4)
(M22)	Data link connector (Terminal No. 5)
(M28)	Combination switch
(M31)	Blower motor
(M58)	Climate controlled seat relay
(M72)	VDC off switch
(M74)	Trunk lid opener cancel switch
(M96)	Heated steering wheel switch
(M102)	Door mirror remote control switch (without automatic drive positioner)
(M109)	Door mirror remote control switch (with automatic drive positioner)
(R3)	Vanity mirror lamp LH
(R4)	Auto anti-dazzling inside mirror (with homelink universal transceiver)
(R6)	Sunroof switch (with single panel sunroof)
(R9)	Vanity mirror lamp RH
(R12)	Personal lamp rear LH
(R13)	Auto anti-dazzling inside mirror (without homelink universal transceiver)
(R14)	Sunroof switch (with dual panel sunroof)
(R101)	Sunroof motor assembly (Terminal No. 2) (with dual panel sunroof)
(R5)	Sunroof motor assembly (Terminal No. 8) (with single panel sunroof)
(R101)	Sunroof motor assembly (Terminal No. 1) (with dual panel sunroof)
(R102)	Sunshade motor assembly (Terminal No. 1) (with dual panel sunroof)
(D4)	Door mirror LH (Terminal No. 7)
(D4)	Door mirror LH (Terminal No. 13)
(D8)	Main power window and door lock/unlock switch (Terminal No. 17)
(D10)	Front door lock assembly LH
(D13)	Seat memory switch
(D15)	Front outside handle LH

ABMIA5298GB

GROUND

< DTC/CIRCUIT DIAGNOSIS >

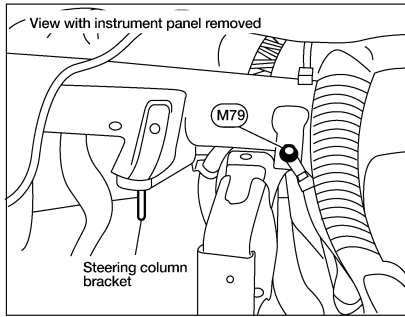

Preceding page

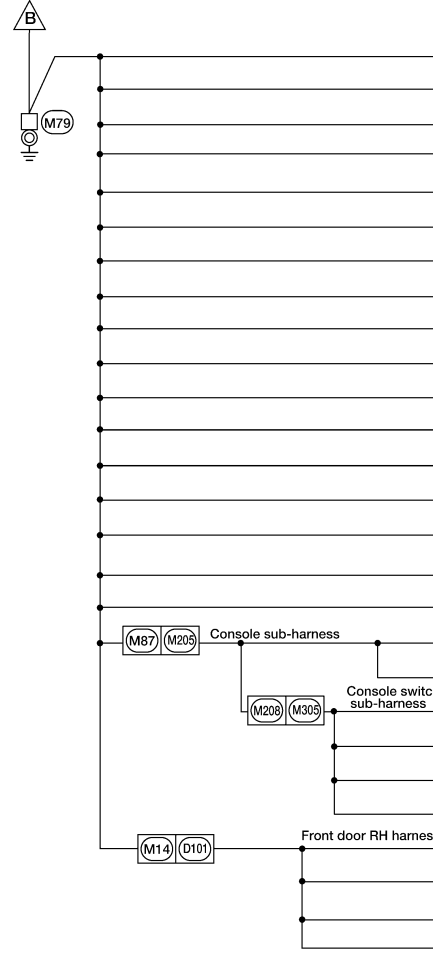

CONNECTOR NUMBER	CONNECT TO
(M5)	Fuse block (J/B)
(M24)	Combination meter (Terminal No. 3)
(M24)	Combination meter (Terminal No. 23)
(M24)	Combination meter (Terminal No. 4)
(M26)	Spiral cable
(M35)	Air bag diagnosis sensor unit (Terminal No. 2) (for Mexico)
(M38)	Push-button ignition switch
(M43)	Air bag diagnosis sensor unit (Terminal No. 2) (except for Mexico)
(M53)	Steering angle sensor
(M54)	Hazard switch
(M55)	Yaw rate/side/decel G sensor
(M78)	CVT shift selector (Terminal No. 4)
(M78)	CVT shift selector (Terminal No. 7)
(M82)	Paddle shifter (shift up)
(M83)	Paddle shifter (shift down)
(M98)	A/C and AV switch assembly
(M169)	Accessory relay-2
(M202)	Front power socket
(M204)	Front console power socket
(M300)	Front heated seat switch RH
(M301)	Front heated seat switch LH
(M302)	Climate controlled seat switch
(M308)	Rear sunshade switch
(D105)	Power window and door lock/unlock switch RH (Terminal No. 11)
(D107)	Door mirror RH (Terminal No. 7)
(D107)	Door mirror RH (Terminal No. 13)
(D115)	Front outside handle RH

ABMIA4025GB

A
B
C
D
E
F
G
H
I
J
K
L
N
O
P

PG

GROUND

< DTC/CIRCUIT DIAGNOSIS >

ENGINE ROOM HARNESS

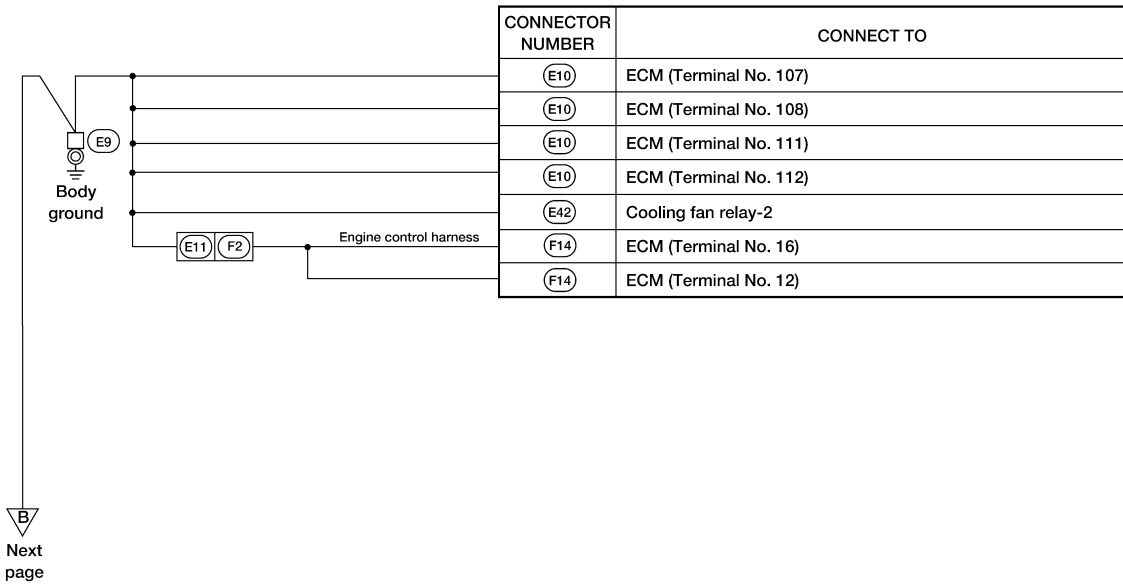
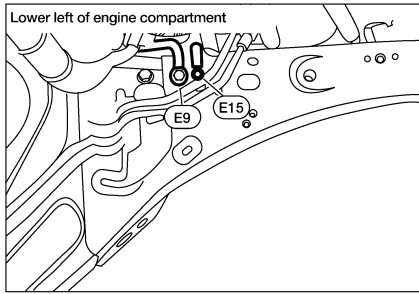

ABMIA3460GB

GROUND

< DTC/CIRCUIT DIAGNOSIS >

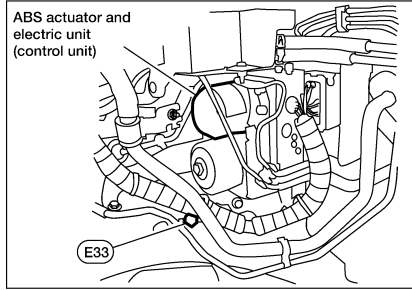
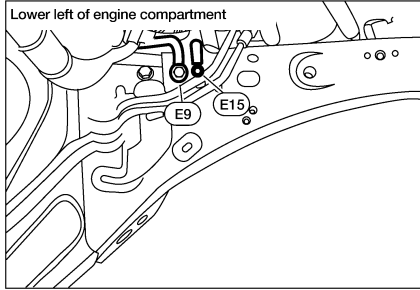

Preceding page

B

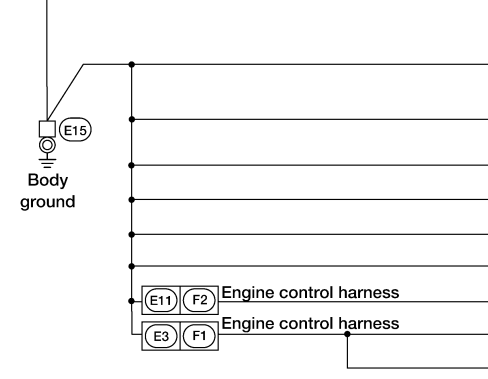

CONNECTOR NUMBER	CONNECT TO
(E17)	IPDM E/R (Intelligent power distribution module engine room) (Terminal No. 41)
(E18)	IPDM E/R (Intelligent power distribution module engine room) (Terminal No. 12)
(E24)	Brake fluid level switch
(E25)	Front wiper motor
(E27)	Shift lock relay
(E43)	Cooling fan relay-3
(F3)	A/C compressor
(F15)	TCM (Transmission control module) (Terminal No. 5)
(F15)	TCM (Transmission control module) (Terminal No. 42)

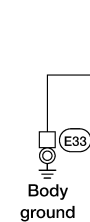

CONNECTOR NUMBER	CONNECT TO
(E26)	ABS actuator and electric unit (Control unit) (Terminal No. 1)
(E26)	ABS actuator and electric unit (Control unit) (Terminal No. 4)

ABMIA3461GB

A
B
C
D
E
F
G
H
I
J
K
L
PG
N
O
P

GROUND

< DTC/CIRCUIT DIAGNOSIS >

FRONT END MODULE HARNESS

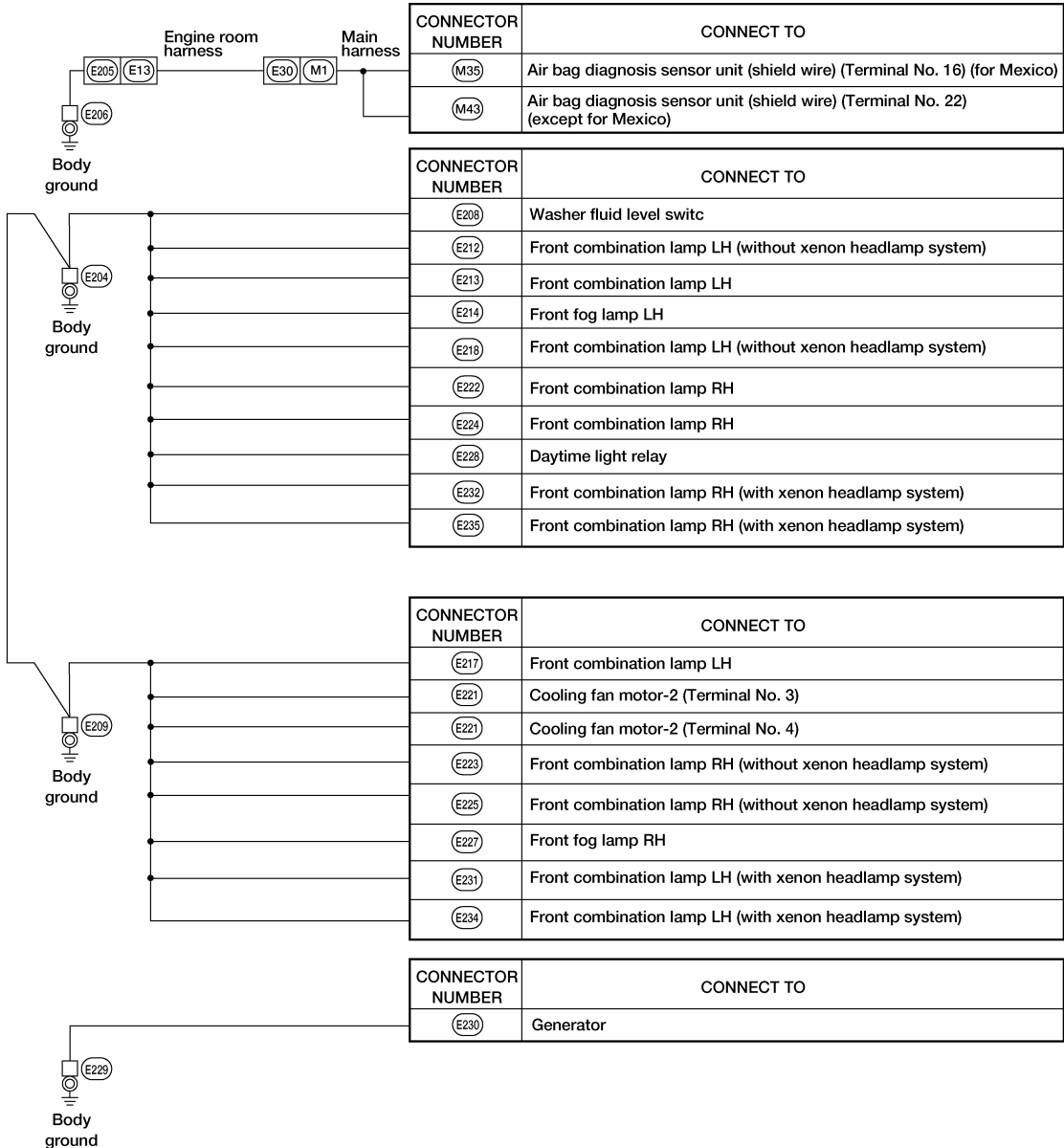
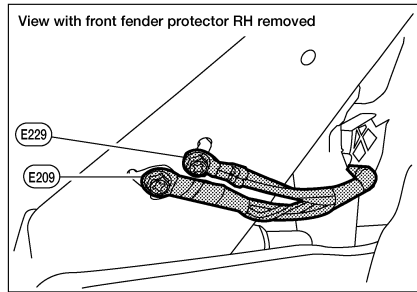
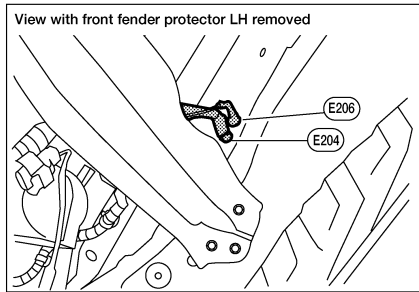

ABMIA5299GB

GROUND

< DTC/CIRCUIT DIAGNOSIS > ENGINE CONTROL HARNESS

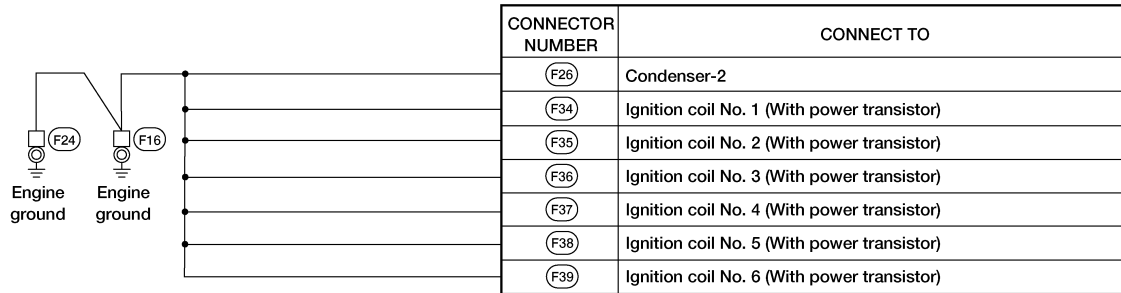
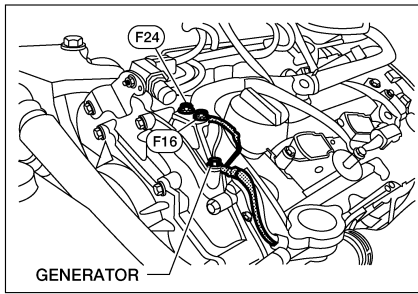

A
B
C
D
E
F
G
H
I
J
K
L
PG
N
O
P

ABMIA5300GB

GROUND

< DTC/CIRCUIT DIAGNOSIS >

BODY HARNESS

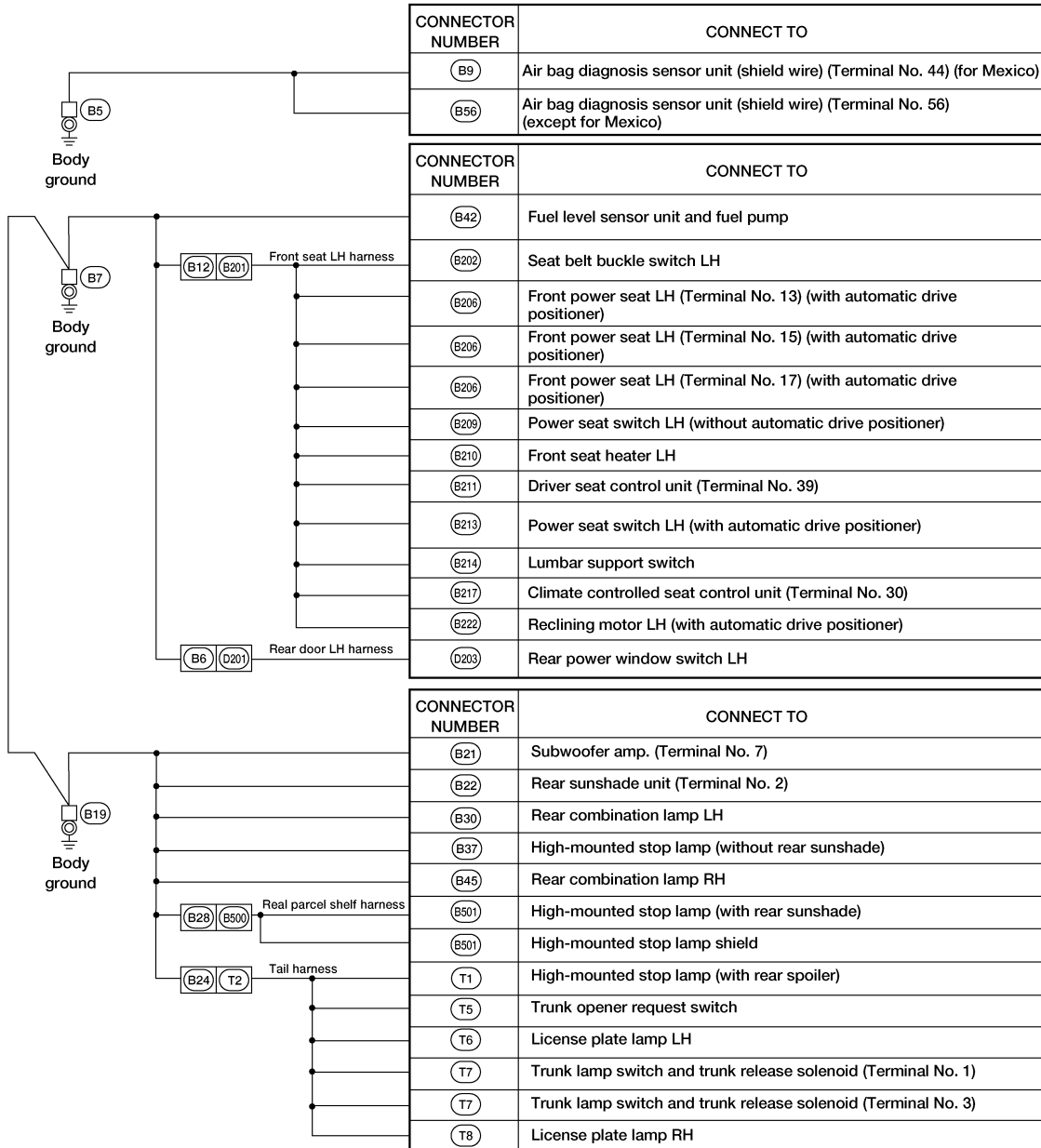
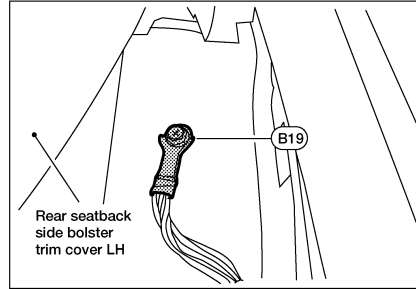
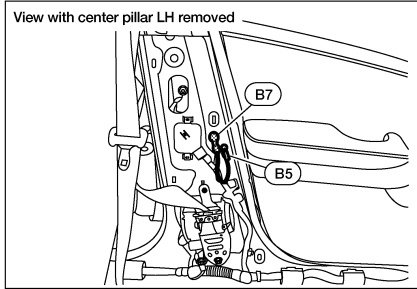

ABMIA5301GB

GROUND

< DTC/CIRCUIT DIAGNOSIS >

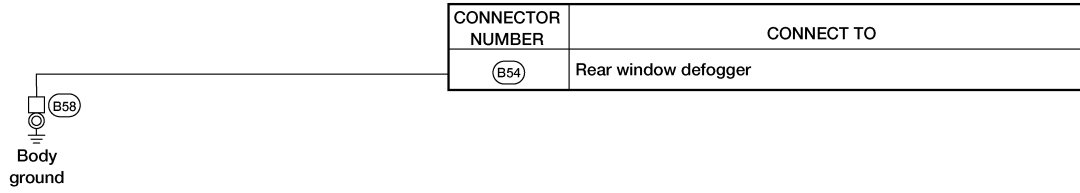
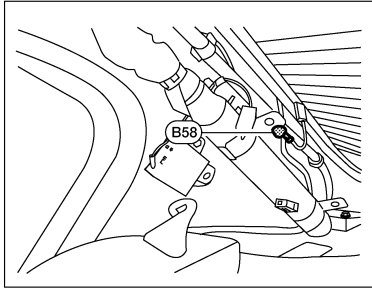

A
B
C
D
E
F
G
H
I
J
K
L
PG
N
O
P

ABMIA4028GB

GROUND

< DTC/CIRCUIT DIAGNOSIS >

BODY NO. 2 HARNESS

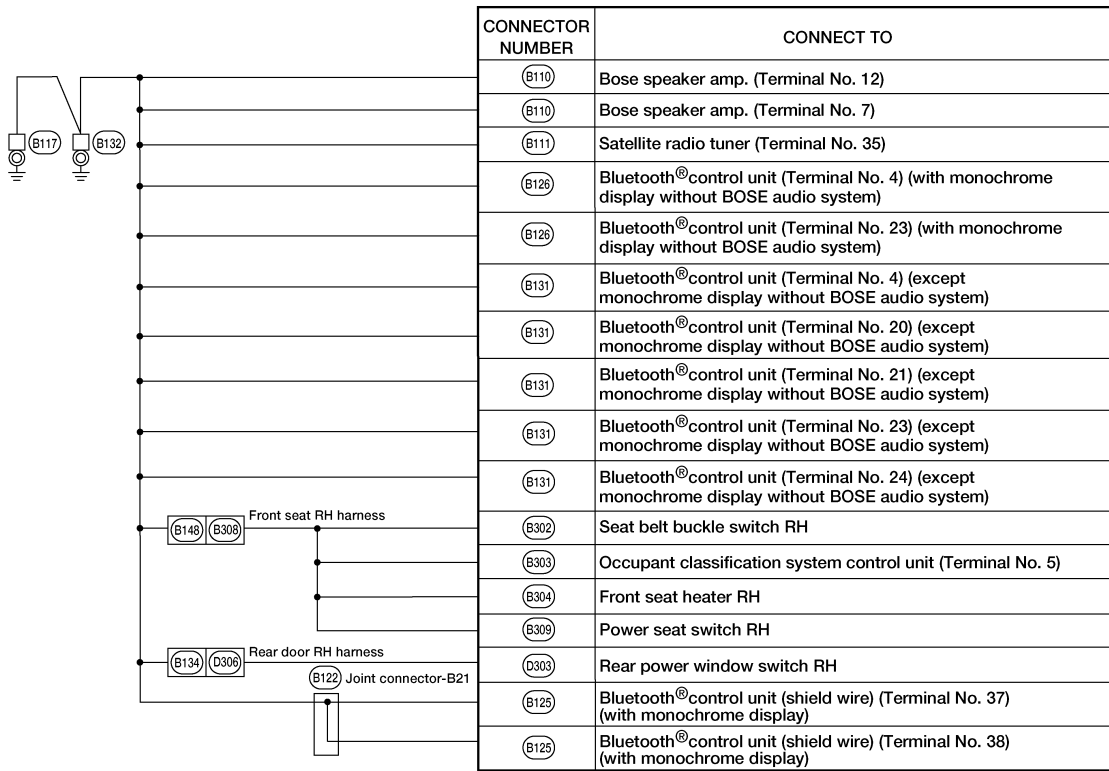
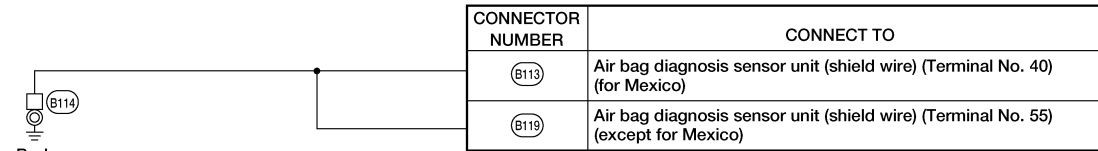
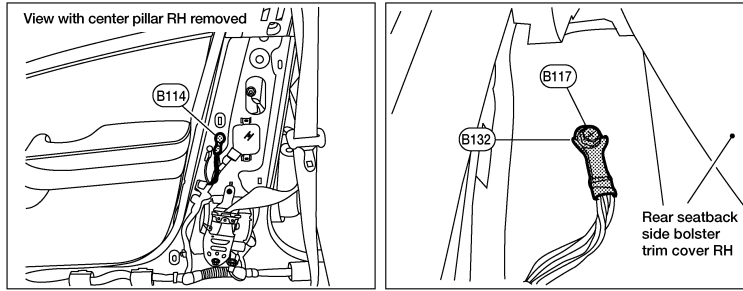

ABMIA5302GB

HARNESS

< DTC/CIRCUIT DIAGNOSIS >

HARNESS

Harness Layout

INFOID:00000009465146

HOW TO READ HARNESS LAYOUT

The following Harness Layouts use a map style grid to help locate connectors on the drawings:

- Main Harness, Console Sub-harness and Console Switch Sub-harness
- Engine Room Harness and Front End Module Harness
- Engine Room Harness (Passenger Compartment)
- Engine Control Harness and Knock Sensor Sub-harness
- Body Harness, Front Seat LH Harness, Tail Harness and Chassis Harness
- Body No. 2 Harness, Front Seat RH Harness, Rear Parcel Shelf Harness and Tail Sub-harness
- Room Lamp Harness and Sunroof Sub-harness

To use the grid reference

1. Find the desired connector number on the connector list.
2. Find the grid reference.
3. On the drawing, find the crossing of the grid reference letter column and number row.
4. Find the connector number in the crossing zone.
5. Follow the line (if used) to the connector.

OUTLINE

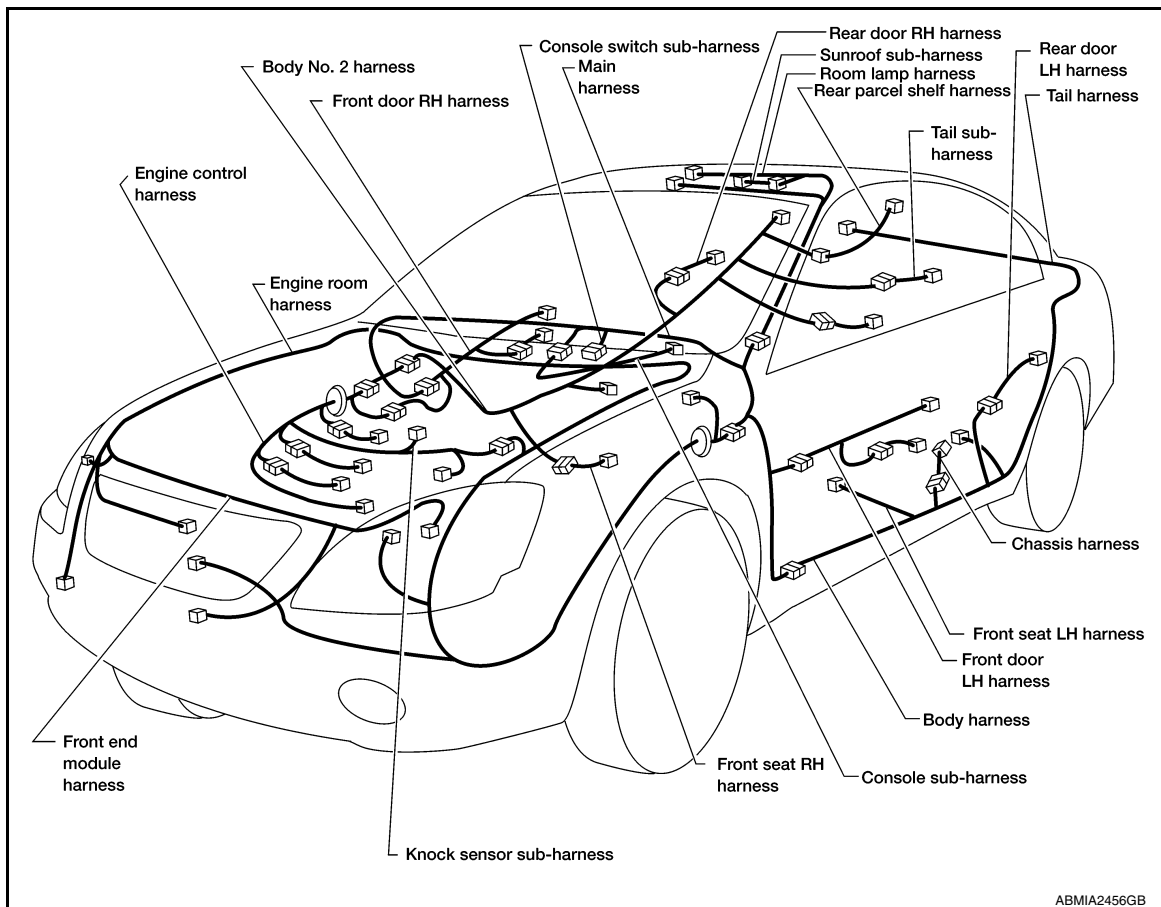

HARNESS

< DTC/CIRCUIT DIAGNOSIS >

MAIN HARNESS

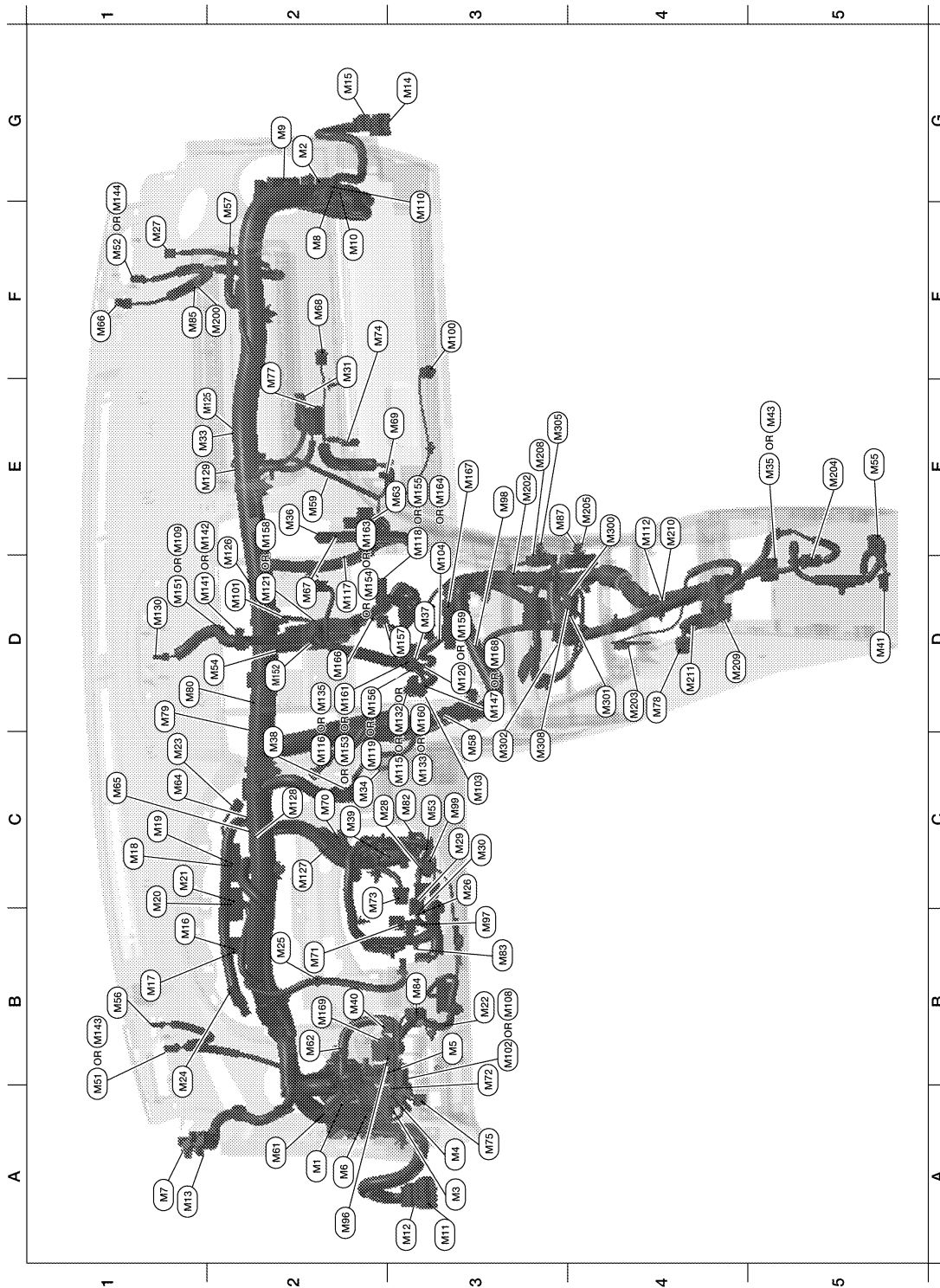

ABMIA5286GB

A2	M1	SMJ	: To E30	B3	M84	W/2	: Circuit breaker
G2	M2	W/24	: To B101	F1	M85	W/24	: To M200
A3	M3	W/8	: Fuse block (J/B)	E4	M87	BR/16	: To M205
A3	M4	W/10	: Fuse block (J/B)	A2	M96	W/6	: Heated steering wheel switch

HARNESS

< DTC/CIRCUIT DIAGNOSIS >

B3	M5	W/12	: Fuse block (J/B)	B3	M97	L/4	: Heated steering relay
A2	M6	SMJ	: To B1	E3	M98	W/16	: A/C and AV switch assembly
A1	M7	W/16	: To R1	C3	M99	BR/2	: Foot lamp LH
F2	M8	W/32	: To B102	F3	M100	BR/2	: Foot lamp RH
G2	M9	BR/16	: To B103	D2	M101	B/10	: A/C display unit
F2	M10	W/16	: To B104	B3	M102	W/16	: Door mirror remote control switch (without automatic drive positioner)
A3	M11	W/16	: To D1	C3	M103	GR/3	: To M501
A3	M12	W/24	: To D2	D3	M104	W/12	: A/C switch assembly
A1	M13	W/6	: To R2	B3	M108	BR/16	: Door mirror remote control switch (with automatic drive positioner)
G2	M14	W/10	: To D101	E1	M109	W/12	: Display unit (with monochrome display)
G2	M15	W/16	: To D102	F3	M110	W/16	: To B136
B1	M16	B/3	: BCM (body control module)	E4	M112	GR/6	: To M210
B1	M17	W/16	: BCM (body control module)	C3	M115	W/20	: AV control unit (color display - without BOSE audio system or navigation system)
C1	M18	G/40	: BCM (body control module)	C2	M116	W/12	: AV control unit (color display - without BOSE audio system or navigation system)
C1	M19	B/40	: BCM (body control module)	D2	M117	W/24	: AV control unit (color display - without BOSE audio system or navigation system)
C1	M20	W/12	: BCM (body control module)	E3	M118	W/16	: AV control unit (color display - without BOSE audio system or navigation system)
C1	M21	GR/40	: BCM (body control module)	C2	M119	W/32	: AV control unit (color display - without BOSE audio system or navigation system)
B3	M22	W/16	: Data link connector	D3	M120	G/4	: AV control unit (color display - without BOSE audio system or navigation system)
C1	M23	W/12	: Combination meter	D2	M121	GR/3	: AV control unit (color display - without BOSE audio system or navigation system)
B1	M24	W/40	: Combination meter	E2	M125	W/3	: To M33
B2	M25	W/8	: Meter mode switch	D2	M126	W/3	: Intake door motor
C3	M26	W/2	: Combination switch (spiral cable)	C2	M127	W/3	: Mode door motor
F1	M27	B/4	: Remote keyless entry receiver	C2	M128	W/3	: Air mix door motor driver side
C3	M28	W/16	: Combination switch	E2	M129	W/3	: Air mix door motor passenger side
C3	M29	Y/6	: Combination switch (spiral cable)	D1	M130	BR/2	: Center speaker
C3	M30	GR/8	: Combination switch (spiral cable)	C3	M132	W/20	: Audio unit (monochrome display - with BOSE audio system)
E2	M31	W/6	: Blower motor	D3	M133	W/20	: Audio unit (monochrome display - without BOSE audio system)
E1	M33	W/3	: To M125	D2	M135	W/12	: Audio unit (monochrome display - with BOSE audio system)
C2	M34	W/2	: In-vehicle sensor	D2	M141	W/24	: Display unit (with color display without navigation system)
E5	M35	Y/28	: Air bag diagnosis sensor unit (for Mexico)	E1	M142	W/24	: Display unit (with color display and navigation system)
E2	M36	W/3	: Front passenger air bag off indicator	B1	M143	BR/2	: Tweeter LH (without BOSE audio system)
D3	M37	W/40	: A/C auto amp.	F1	M144	BR/2	: Tweeter RH (without BOSE audio system)
C2	M38	BR/8	: Push-button ignition switch	D3	M147	W/12	: Audio unit (monochrome display - without BOSE audio system)
C2	M39	GR/6	: ADP steering switch	D1	M151	G/4	: Display unit (with color display and navigation system)

HARNESSES

< DTC/CIRCUIT DIAGNOSIS >

B2	M40	W/12	: Key slot	D2	M152	W/20	: AV control unit (color display - with BOSE audio system without navigation system)
D5	M41	GR/2	: Front console antenna	C2	M153	W/12	: AV control unit (color display - with BOSE audio system without navigation system)
E5	M43	Y/28	: Air bag diagnosis sensor unit (except for Mexico)	D2	M154	W/24	: AV control unit (color display - with BOSE audio system without navigation system)
B1	M51	BR/2	: Tweeter LH (with BOSE audio system)	E3	M155	W/16	: AV control unit (color display - with BOSE audio system without navigation system)
F1	M52	BR/2	: Tweeter RH (with BOSE audio system)	D2	M156	W/32	: AV control unit (color display - with BOSE audio system without navigation system)
C3	M53	W/8	: Steering angle sensor	D3	M157	W/12	: AV control unit (color display - with BOSE audio system without navigation system)
D2	M54	W/4	: Hazard switch	D2	M158	GR/3	: AV control unit (color display - with BOSE audio system without navigation system)
E5	M55	B/4	: Yaw rate/side/decel G sensor	D3	M159	G/4	: AV control unit (color display - with BOSE audio system without navigation system)
B1	M56	B/2	: Sunload sensor	C3	M160	W/20	: AV control unit (color display - with BOSE audio system and navigation system)
F2	M57	—	: Body ground	D2	M161	G/4	: AV control unit (color display - with BOSE audio system and navigation system)
C3	M58	L/4	: Climate controlled seat relay	E2	M163	W/32	: AV control unit (color display - with BOSE audio system and navigation system)
E2	M59	W/12	: Power steering control unit	E3	M164	W/40	: AV control unit (color display - with BOSE audio system and navigation system)
A2	M61	—	: Body ground	D2	M166	GR/3	: AV control unit (color display - with BOSE audio system and navigation system)
B2	M62	W/2	: Tire pressure warning check connector	E3	M167	G/4	: AV control unit (color display - with BOSE audio system and navigation system)
E3	M63	W/24	: Automatic drive positioner control unit	D3	M168	W/28	: AV control unit (color display - with BOSE audio system and navigation system)
C1	M64	W/4	: Joint connector-M01	B2	M169	L/4	: Accessory relay-2
C1	M65	GR/6	: Joint connector-M02	Console sub-harness			
F1	M66	W/3	: Optical sensor	F2	M200	W/24	: To M85
D2	M67	W/6	: Automatic drive positioner control unit	E3	M202	B/3	: Front power socket
F2	M68	BR/2	: Glove box lamp	D4	M203	BR/2	: CVT shift selector
E3	M69	W/2	: Intake sensor	E5	M204	B/3	: Front console power socket
C2	M70	W/4	: Tire pressure receiver	E4	M205	BR/16	: To M87
B2	M71	W/6	: Tilt motor	E3	M208	W/16	: To M305
B3	M72	GR/6	: VDC OFF switch	D4	M209	W/8	: Aux in jack
C2	M73	W/6	: Telescopic motor	E4	M210	GR/6	: To M112
E2	M74	W/2	: Trunk lid opener cancel switch	D4	M211	G/4	: USB interface
A3	M75	B/2	: Trunk lid opener switch	Console switch sub-harness			
E2	M77	Y/4	: Front passenger air bag module	E4	M300	BR/6	: Front heated seat switch RH
D4	M78	W/10	: CVT shift selector	D4	M301	W/6	: Front heated seat switch LH
D1	M79	—	: Body ground	C3	M302	W/10	: Climate controlled seat switch
D1	M80	B/2	: Diode-3	E3	M305	W/16	: To M208
C3	M82	W/4	: Paddle shifter (shift up)	C3	M308	W/6	: Rear sunshade switch
B3	M83	W/3	: Paddle shifter (shift down)				

HARNESS

< DTC/CIRCUIT DIAGNOSIS >

ENGINE ROOM HARNESS

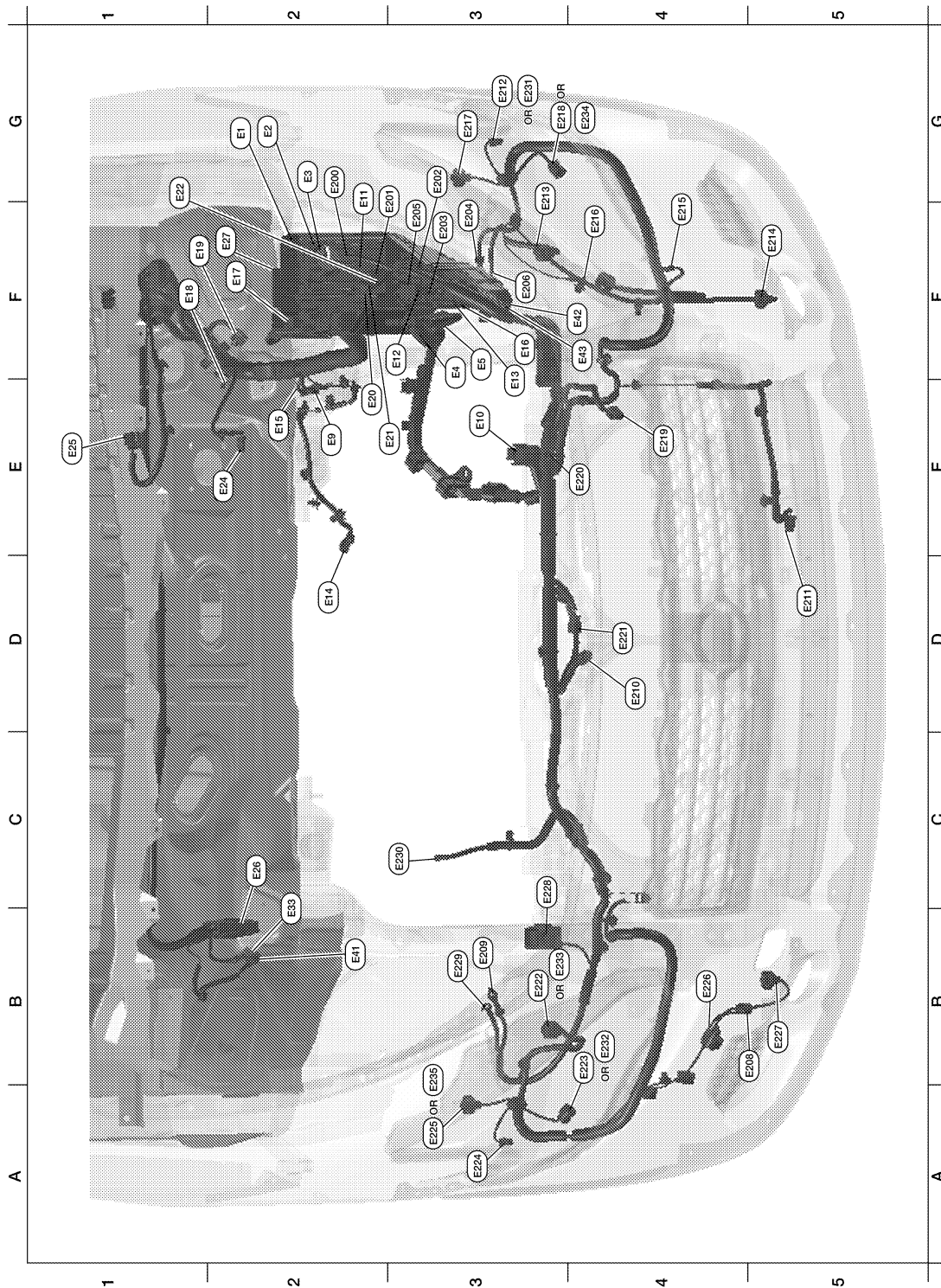

ABMIA1451GB

G2	E1	W/6	: Joint connector-E01	F3	E204	—	: Body ground
G2	E2	W/8	: To E202	F3	E205	B/3	: To E13
G2	E3	W/16	: To F1	F3	E206	—	: Body ground
F3	E4	BR/2	: Fusible link box (battery)	B4	E208	W/2	: Washer fluid level switch
F3	E5	GR/2	: Fusible link box (battery)	B3	E209	—	: Body ground

HARNESS

< DTC/CIRCUIT DIAGNOSIS >

E2	E9	—	: Body ground	D4	E210	Y/2	: Crash zone sensor
E3	E10	B/32	: ECM	D5	E211	B/2	: Ambient sensor
G2	E11	W/10	: To F2	G3	E212	B/2	: Front combination lamp LH (without xenon headlamp system)
F3	E12	W/6	: To E203	F3	E213	B/2	: Front combination lamp LH
F3	E13	B/3	: To E205	F5	E214	B/2	: Front fog lamp LH
D2	E14	B/2	: Power steering solenoid valve	F4	E215	B/1	: Horn (low)
E2	E15	—	: Body ground	F4	E216	B/1	: Horn (high)
F3	E16	B/2	: IPDM E/R (intelligent power distribution module engine room)	G3	E217	GR/3	: Front combination lamp LH
F2	E17	W/8	: IPDM E/R (intelligent power distribution module engine room)	G3	E218	GR/2	: Front combination lamp LH (without xenon headlamp system)
F1	E18	W/36	: IPDM E/R (intelligent power distribution module engine room)	E4	E219	B/3	: Refrigerant pressure sensor
F1	E19	GR/2	: Front wheel sensor LH	E4	E220	GR/4	: Cooling fan motor-1
E2	E20	W/6	: Joint connector-E02	D4	E221	GR/4	: Cooling fan motor-2
E2	E21	W/4	: Joint connector-E03	B3	E222	B/2	: Front combination lamp RH (without daytime light system)
G1	E22	W/4	: Joint connector-E04	B4	E223	B/2	: Front combination lamp RH (without xenon headlamp system)
E2	E24	GR/2	: Brake fluid level switch	A3	E224	GR/3	: Front combination lamp RH
E1	E25	GR/5	: Front wiper motor	A3	E225	GR/2	: Front combination lamp RH (without xenon headlamp system)
C2	E26	B/26	: ABS actuator and electric unit (control unit)	B4	E226	B/2	: Front washer motor
F2	E27	L/4	: Shift lock relay	B5	E227	B/2	: Front fog lamp RH
B2	E33	—	: Body Ground	C3	E228	B/5	: Daytime light relay
B2	E41	GR/2	: Front wheel sensor RH	B3	E229	—	: Body ground
F4	E42	BR/6	: Cooling fan relay-2	C3	E230	—	: Generator
F4	E43	BR/6	: Cooling fan relay-3	G3	E231	GR/2	: Front combination lamp LH (with xenon headlamp system)
Front end module harness				B4	E232	GR/2	: Front combination lamp RH (with xenon headlamp system)
G2	E200	W/8	: IPDM E/R (intelligent power distribution module engine room)	B3	E233	B/2	: Front combination lamp RH (with daytime light system)
G2	E201	W/16	: IPDM E/R (intelligent power distribution module engine room)	G4	E234	GR/2	: Front combination lamp LH (with xenon headlamp system)
G3	E202	W/8	: To E2	B3	E235	GR/2	: Front combination lamp RH (with xenon headlamp system)
F3	E203	W/6	: To E12				

HARNESS

< DTC/CIRCUIT DIAGNOSIS >

ENGINE ROOM HARNESS (PASSENGER COMPARTMENT)

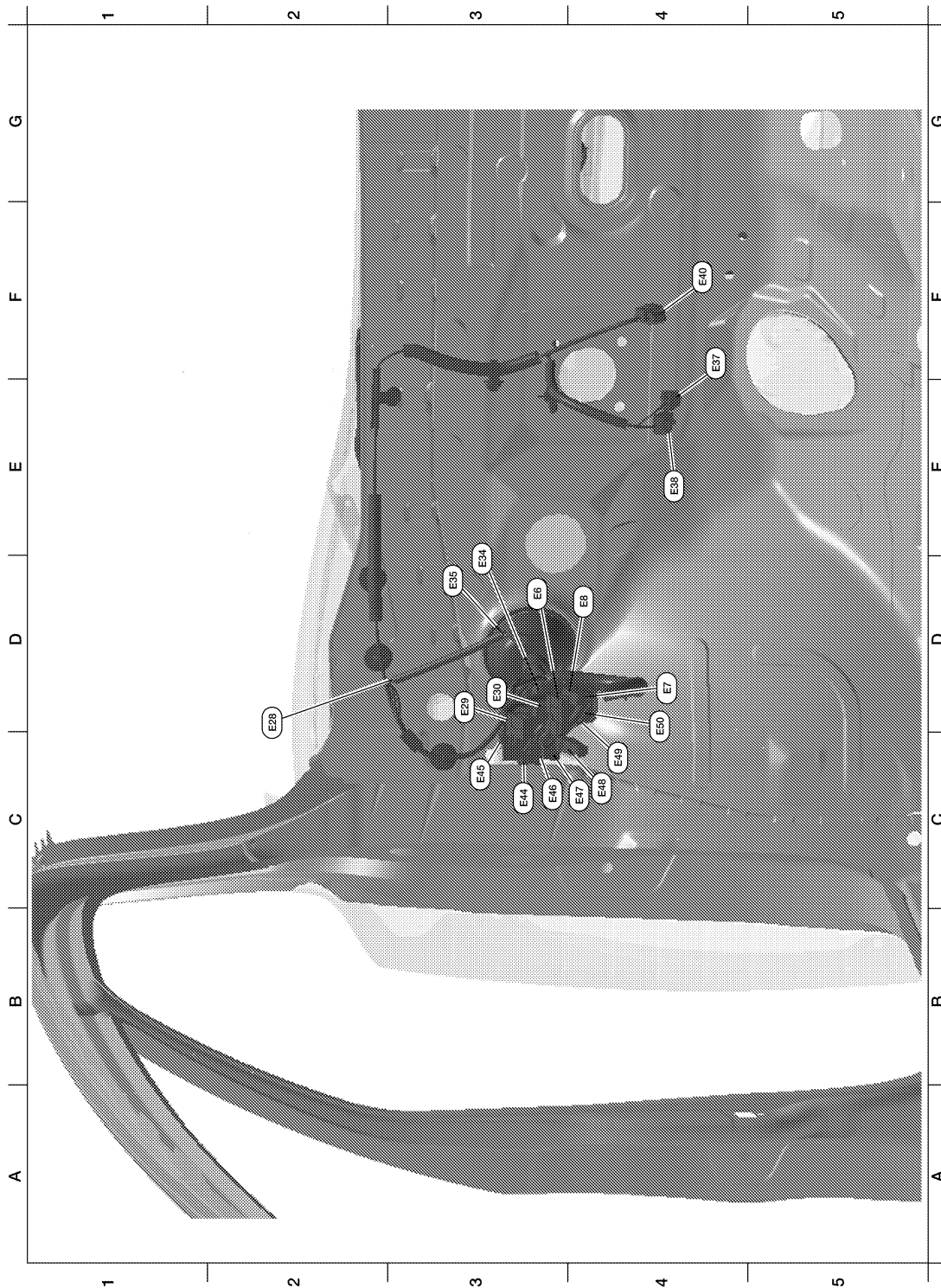

ABMIA0289GB

D3	E6	W/16	: Fuse block (J/B)	E4	E38	W/4	: Stop lamp switch
D4	E7	W/1	: Fuse block (J/B)	F4	E40	B/6	: Accelerator pedal position sensor
D4	E8	B/2	: Fuse block (J/B)	C3	E44	BR/12	: Junction block
D2	E28	BR/3	: Intelligent Key warning buzzer	C3	E45	W/12	: Junction block
D3	E29	W/16	: To B10	C3	E46	W/16	: Junction block

A
B
C
D
E
F
G
H
I
J
K
L
M
N
O
P

PG

HARNESS

< DTC/CIRCUIT DIAGNOSIS >

D3	E30	SMJ	: To M1	C4	E47	W/6	: Junction block
D3	E34	L/4	: Back-up lamp relay	C4	E48	W/4	: Junction block
D3	E35	B/1	: Parking brake switch	C4	E49	BR/4	: Junction block
F4	E37	BR/2	: Brake pedal position switch	D4	E50	W/2	: Junction block

ENGINE CONTROL HARNESS

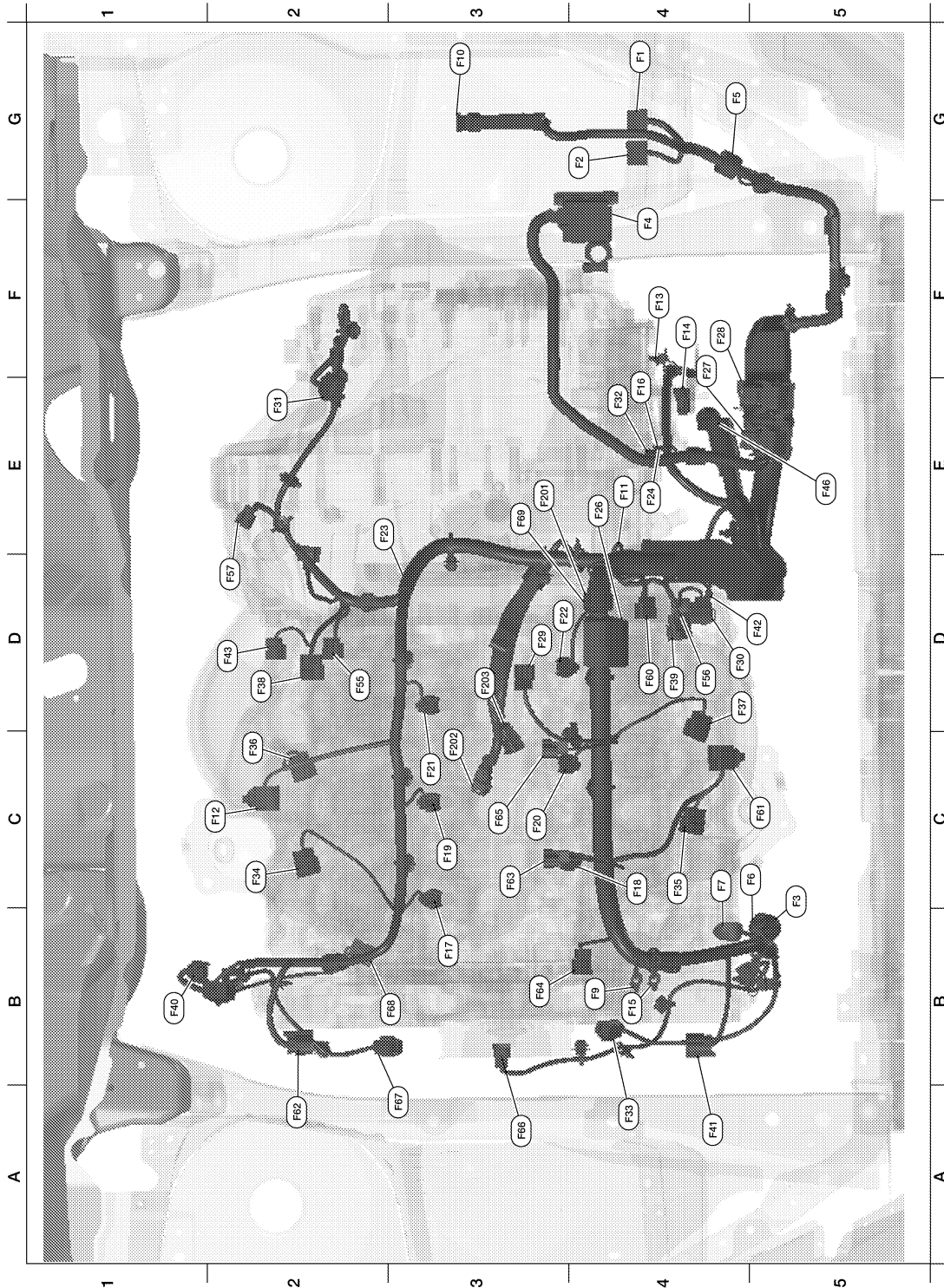

ABMIA5287ZZ

HARNESS

< DTC/CIRCUIT DIAGNOSIS >

G4	F1	W/16	: To E3	A4	F33	L/4	: Exhaust valve timing control magnet retarder (bank 2)	A	
G4	F2	W/10	: To E11	C2	F34	GR/3	: Ignition coil No. 1 (with power transistor)	B	
C5	F3	B/2	: A/C Compressor	C4	F35	GR/3	: Ignition coil No. 2 (with power transistor)	B	
F4	F4	—	: Fusible link box (battery)	C2	F36	GR/3	: Ignition coil No. 3 (with power transistor)	C	
G4	F5	B/3	: Battery current sensor	D4	F37	GR/3	: Ignition coil No. 4 (with power transistor)	C	
C5	F6	—	: Generator	D2	F38	GR/3	: Ignition coil No. 5 (with power transistor)	D	
C4	F7	B/3	: Generator	D4	F39	GR/3	: Ignition coil No. 6 (with power transistor)	D	
B4	F9	—	: Engine ground	B1	F40	B/3	: Power steering pressure sensor	D	
G3	F10	W/36	: IPDM E/R (intelligent power distribution module engine room)	A4	F41	GR/1	: Oil pressure switch	E	
E4	F11	GR/2	: Engine coolant temperature sensor	D5	F42	B/3	: Exhaust valve timing control position sensor (bank 2)	E	
C2	F12	GR/4	: Air fuel ratio (A/F) sensor 1 (bank 1)	D2	F43	B/3	: Exhaust valve timing control position sensor (bank 1)	F	
F4	F13	BR/48	: ECM	E5	F46	B/22	: CVT unit	F	
F4	F14	GR/32	: ECM	D2	F55	B/3	: Camshaft position sensor (PHASE) (bank 1)	G	
B4	F15	B/48	: TCM (transmission control module)	D4	F56	B/4	: Heated oxygen sensor 2 (bank 2)	G	
E4	F16	—	: Engine ground	D2	F57	B/6	: Electric throttle control actuator	H	
B3	F17	GR/2	: Fuel injector No. 1	D4	F60	B/3	: Camshaft position sensor (PHASE) (bank 2)	H	
C4	F18	GR/2	: Fuel injector No. 2	C5	F61	GR/4	: Air fuel ratio (A/F) sensor 1 (bank 2)	I	
C3	F19	GR/2	: Fuel injector No. 3	A2	F62	B/4	: Heated oxygen sensor 2 (bank 1)	I	
C3	F20	GR/2	: Fuel injector No. 4	C3	F63	B/2	: VIAS control solenoid valve 1	J	
C3	F21	GR/2	: Fuel injector No. 5	B3	F64	BR/2	: Electronic controlled engine mount controlled solenoid valve	J	
D3	F22	GR/2	: Fuel injector No. 6	C3	F65	B/2	: VIAS control solenoid valve 2	K	
E2	F23	B/3	: Secondary speed sensor	A3	F66	G/2	: Intake valve timing control solenoid valve (bank 2)	K	
E4	F24	—	: Engine ground	A3	F67	G/2	: Intake valve timing control solenoid valve (bank 1)	L	
E4	F26	W/2	: Condenser-2	B2	F68	GR/2	: Engine oil temperature sensor	L	
F4	F27	—	: Starter motor	E3	F69	L/4	: To F201	L	
F4	F28	GR/1	: Starter motor	Knock sensor sub-harness					
D3	F29	L/2	: EVAP canister purge volume control solenoid valve	E3	F201	L/4	: To F69	PG	
D4	F30	B/3	: Crankshaft position sensor (POS)	C3	F202	GR/2	: Knock sensor (bank 1)		
E2	F31	B/6	: Mass air flow sensor	D3	F203	GR/2	: Knock sensor (bank 2)	N	
E4	F32	L/4	: Exhaust valve timing control magnet retarder (bank 1)					O	

HARNESS

< DTC/CIRCUIT DIAGNOSIS >

BODY HARNESS



ABMIA4035GB

B1	B1	SMJ	: To M6	E3	B54	B/1	: Rear window defogger
B2	B2	B/6	: Joint connector-B01	E3	B55	—	: Body ground
B3	B3	W/4	: Joint connector-B02	D2	B56	Y/22	: Air bag diagnosis sensor unit (except for Mexico)
B2	B4	BR/12	: Fuse block (J/B)	F2	B58	—	: Body ground
C2	B5	—	: Body ground	E3	B71	Y/2	: LH side curtain air bag module

HARNESS

< DTC/CIRCUIT DIAGNOSIS >

C2	B6	W/10	: To D201	Front seat LH harness			
C2	B7	—	: Body ground	B2	B201	W/8	: To B12
B2	B8	W/3	: Front door switch LH	C2	B202	W/3	: Seat belt buckle switch LH
C2	B9	Y/12	: Air bag diagnosis sensor unit (for Mexico)	C3	B203	W/32	: Driver seat control unit
B1	B10	W/16	: To E29	C3	B204	W/6	: Front power seat LH (without automatic drive positioner)
C2	B11	Y/2	: Front LH side air bag module	D3	B205	W/6	: Front power seat LH (with automatic drive positioner)
B2	B12	W/8	: To B201	B3	B206	W/12	: Front power seat LH (with automatic drive positioner)
C4	B13	W/4	: Joint connector-B03	D2	B207	B/2	: Reclining motor (without automatic drive positioner)
B3	B14	Y/2	: Front LH seat belt pre-tensioner	B2	B208	W/16	: To B32
C3	B15	Y/2	: LH side air bag (satellite) sensor	B3	B209	W/10	: Power seat switch LH (without automatic drive positioner)
E3	B16	W/2	: Subwoofer LH	C2	B210	W/3	: Front seat heater LH
F2	B17	W/2	: Subwoofer RH	C3	B211	W/12	: Driver seat control unit
D3	B18	W/3	: Rear door switch LH	C3	B212	B/16	: Climate controlled seat control unit
D3	B19	—	: Body ground	B3	B213	W/10	: Power seat switch LH (with automatic drive positioner)
F3	B20	L/20	: Joint connector-B05	C3	B214	W/4	: Lumbar support switch
F3	B21	W/10	: Subwoofer amp.	D3	B216	B/8	: Climate controlled seat control unit
F3	B22	W/6	: Rear sunshade unit	D3	B217	B/6	: Climate controlled seat control unit
F3	B24	W/8	: To T2	C2	B218	W/4	: Seat back thermal electric device
E3	B26	W/4	: Joint connector-B04	C2	B219	W/4	: Seat cushion thermal electric device
D4	B27	W/4	: Fuel lid door lock actuator	D2	B220	W/5	: Climate controlled seat blower motor
D3	B28	W/3	: To B500	C3	B221	B/2	: Lumbar support Motor
E3	B29	GR/2	: Rear parcel shelf antenna	D2	B222	B/5	: Reclining motor LH (with automatic drive positioner)
E4	B30	W/6	: Rear combination lamp LH	Tail harness			
E4	B31	GR/4	: To C5	F3	T1	BR/2	: High-mounted stop lamp (with rear spoiler)
B2	B32	W/16	: To B208	F4	T2	W/8	: To B24
E3	B36	W/2	: Trunk room lamp	G3	T5	BR/2	: Trunk opener request switch
F3	B37	W/2	: High-mounted stop lamp (without rear sunshade)	F4	T6	BR/2	: Licence plate lamp LH
E3	B39	B/2	: EVAP canister vent control valve	F4	T7	W/4	: Trunk lamp switch and trunk release solenoid
E3	B41	GR/3	: EVAP control system pressure sensor	G3	T8	BR/2	: Licence plate lamp RH
D3	B42	GR/5	: Fuel level sensor unit and fuel pump	Chassis harness			
G2	B45	W/6	: Rear combination lamp RH	E4	C1	B/2	: Rear wheel sensor LH
F4	B46	GR/2	: Rear bumper antenna	F3	C2	GR/2	: Rear wheel sensor RH
D3	B52	W/1	: Rear window defogger condenser	E4	C5	GR/4	: To B31
D3	B53	B/1	: Rear window defogger				

A
B
C
D
E
F
G
H
I
J
K
L
PG
N
O
P

HARNESS

< DTC/CIRCUIT DIAGNOSIS >

BODY NO. 2 HARNESS

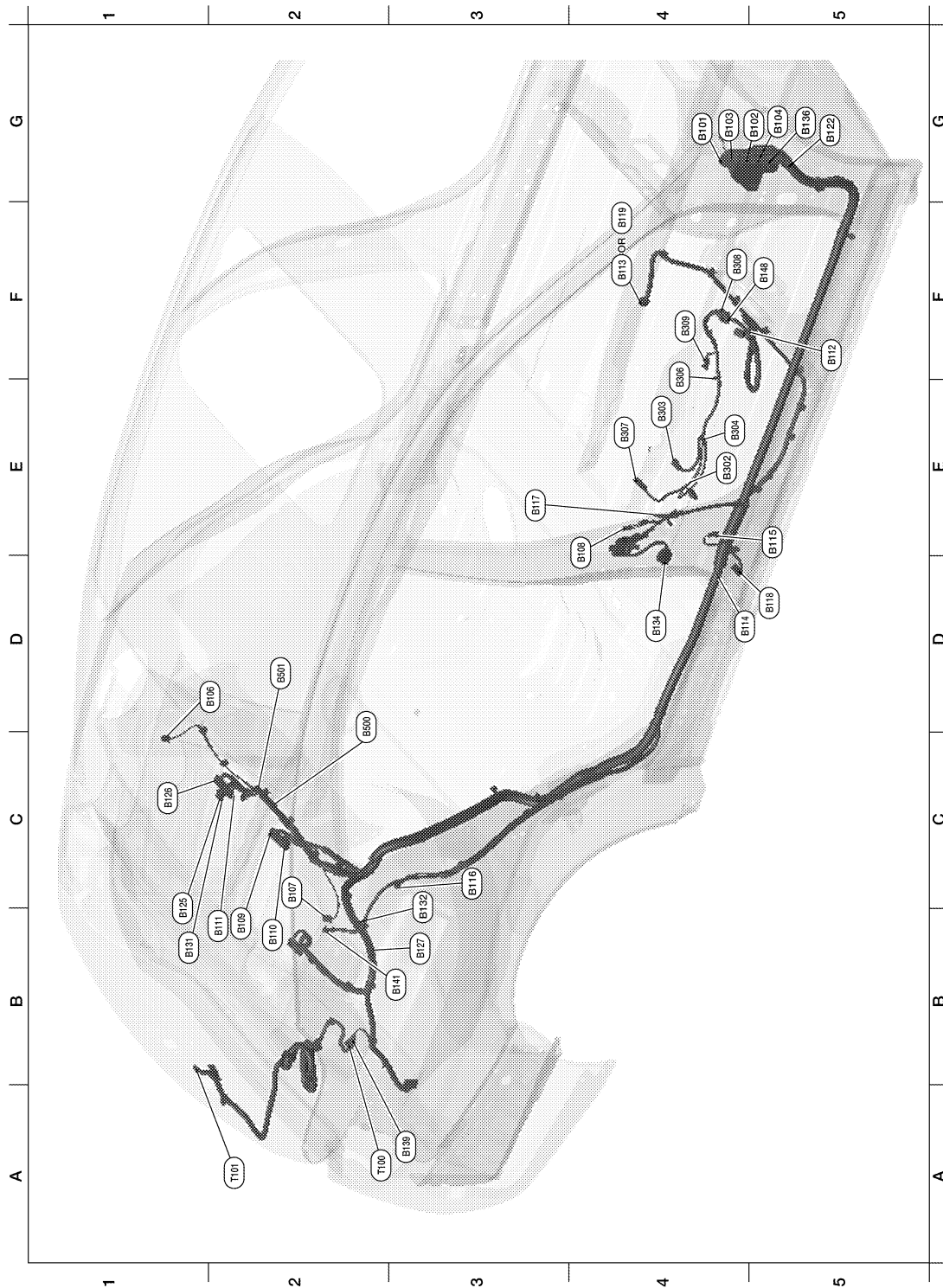

ABMIA4036GB

G4	B101	W/24	: To M2	B1	B131	W/32	: Bluetooth® control unit (except monochrome display without BOSE audio system)
G5	B102	W/32	: To M8	B3	B132	—	: Body ground
G4	B103	BR/16	: To M9	D4	B134	W/10	: To D306
G5	B104	W/16	: To M10	G5	B136	W/16	: To M110

HARNESS

< DTC/CIRCUIT DIAGNOSIS >

D2	B106	W/2	: Rear subwoofer LH	A3	B139	W/4	: To T100	A
C2	B107	W/2	: Rear subwoofer RH	B3	B141	Y/2	: RH side curtain air bag module	B
E4	B108	W/3	: Front door switch RH	F5	B148	W/8	: To B308	C
B2	B109	BR/23	: BOSE speaker amp.	Front seat RH harness				B
B2	B110	BR/14	: BOSE speaker amp.	E4	B302	W/3	: Seat belt buckle switch RH	C
B2	B111	W/16	: Satellite radio tuner	E4	B303	W/8	: Occupant classification system control unit	D
F5	B112	Y/2	: Front RH side air bag module	E4	B304	W/3	: Front seat heater RH	E
F4	B113	Y/12	: Air bag diagnosis sensor unit (for Mexico)	F4	B306	GR/3	: Sliding motor RH	F
D4	B114	—	: Body ground	E4	B307	B/2	: Reclining motor RH	G
E5	B115	Y/2	: Front RH seat belt pre-tensioner	F4	B308	W/8	: To B148	H
C3	B116	W/3	: Rear door switch RH	F4	B309	W/10	: Power seat switch RH	I
E3	B117	—	: Body ground	Rear parcel shelf harness				J
D5	B118	Y/2	: RH side air bag (satellite) sensor	D2	B500	W/3	: To B28	K
F4	B119	Y/22	: Air bag diagnosis sensor unit (except for Mexico)	D2	B501	GR/2	: High-mounted stop lamp (with rear sunshade)	L
G5	B122	W/4	: Joint connector-B21	Tail sub-harness				M
B1	B125	W/8	: Bluetooth® control unit	A2	T100	W/4	: To B139	N
C1	B126	W/32	: Bluetooth® control unit (with monochrome display without BOSE audio system)	A2	T101	W/4	: Rear view camera	O
B3	B127	—	: Body ground					P

PG

HARNESS

< DTC/CIRCUIT DIAGNOSIS >

ROOM LAMP HARNESS

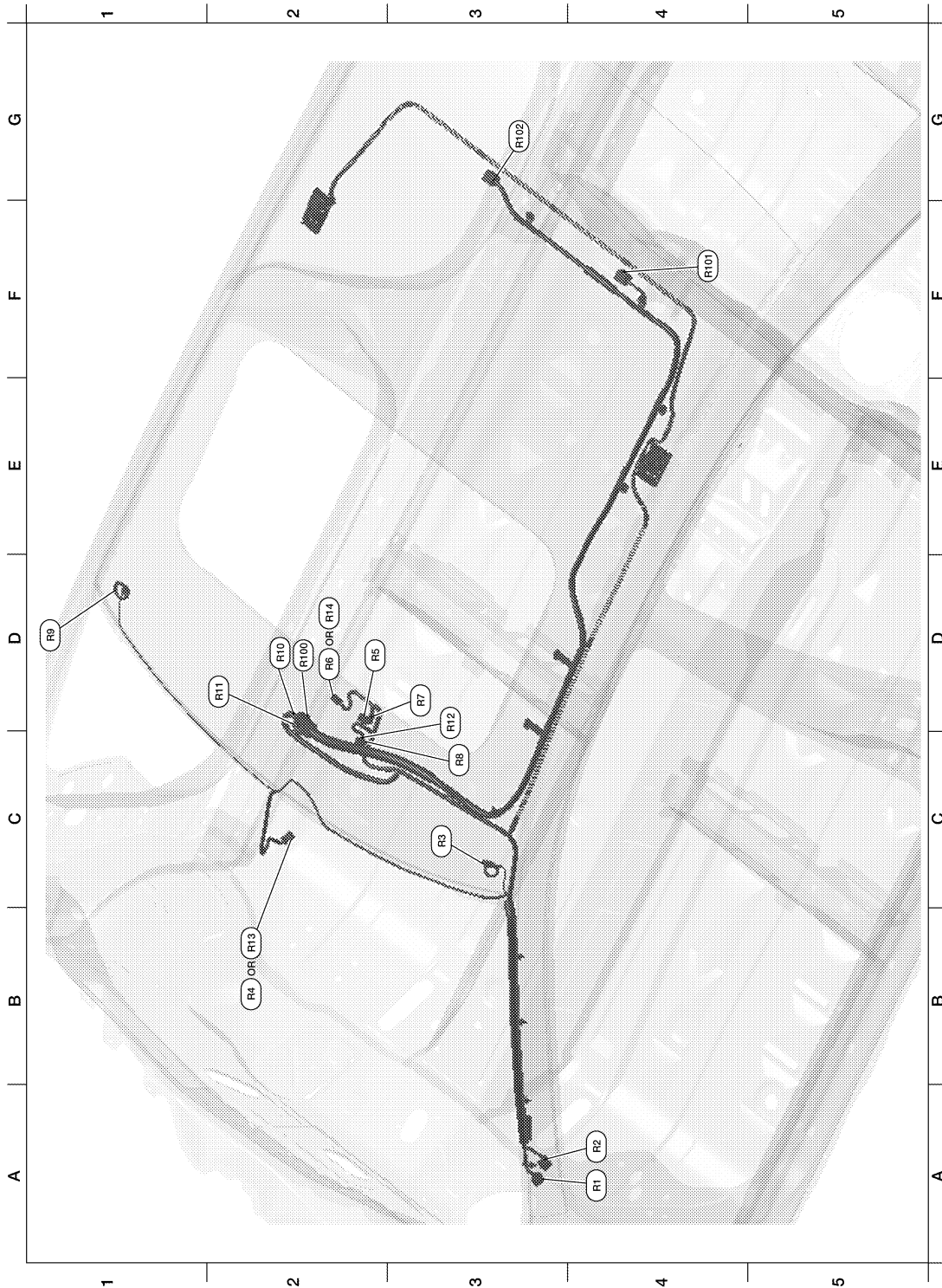

ABMIA4048GB

A4	R1	W/16	: To M7	D2	R10	W/12	: To R100
A4	R2	W/6	: To M13	D2	R11	W/8	: Personal lamp rear RH
C3	R3	W/2	: Vanity mirror lamp LH	D3	R12	W/8	: Personal lamp rear LH
B2	R4	B/10	: Auto anti-dazzling inside mirror (with homelink universal transceiver)	B2	R13	B/7	: Auto anti-dazzling inside mirror (without homelink universal transceiver)

HARNESS

< DTC/CIRCUIT DIAGNOSIS >

D2	R5	W/10	: Sunroof motor assembly (without dual panel sunroof)	D2	R14	W/8	: Sunroof switch (with dual panel sunroof)
D2	R6	W/3	: Sunroof switch (without dual panel sunroof)	Sunroof sub-harness			
D3	R7	W/4	: Microphone	D2	R100	W/12	: To R10
C3	R8	GR/6	: Front room/map lamp assembly	F4	R101	GR/10	: Sunroof motor assembly (with dual panel sunroof)
D1	R9	W/2	: Vanity mirror lamp RH	G3	R102	GR/10	: Sunshade motor assembly (with dual panel sunroof)

FRONT DOOR LH HARNESS

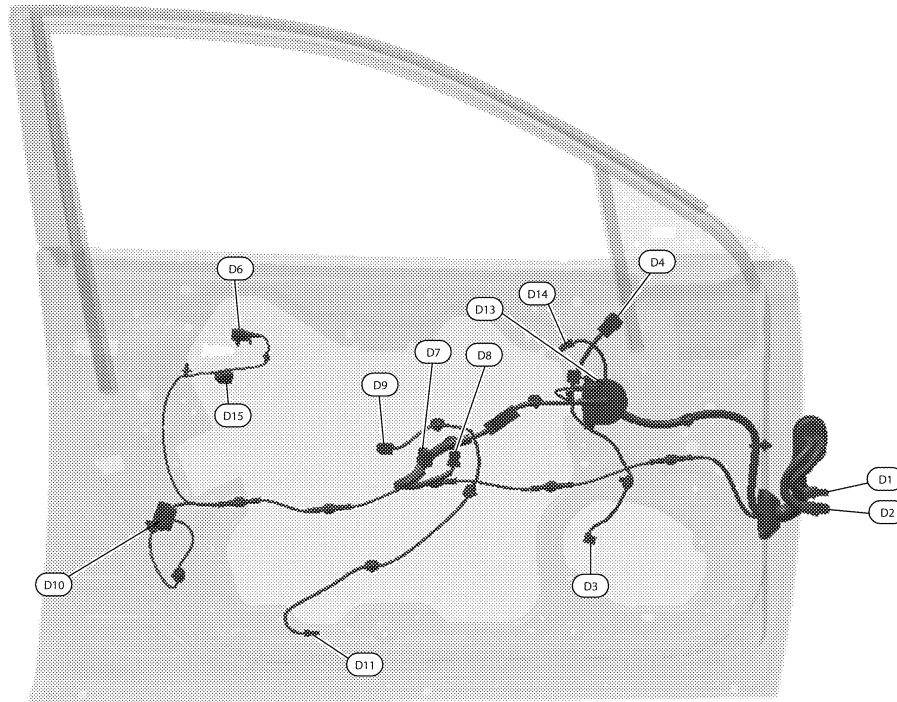

ABMIA0294GB

D1	W/16	: To M11	D9	W/6	: Front power window motor LH
D2	W/24	: To M12	D10	GR/6	: Front door lock assembly LH
D3	W/2	: Front door speaker LH	D11	W/2	: Front step lamp LH
D4	W/16	: Door mirror LH	D13	W/8	: Seat memory switch
D6	GR/2	: Front outside handle LH (outside key antenna)	D14	GR/2	: Front door inside handle illumination LH
D7	W/16	: Main power window and door lock/unlock switch	D15	B/2	: Front outside handle LH (request switch)
D8	W/3	: Main power window and door lock/unlock switch			

HARNESS

< DTC/CIRCUIT DIAGNOSIS >

FRONT DOOR RH HARNESS

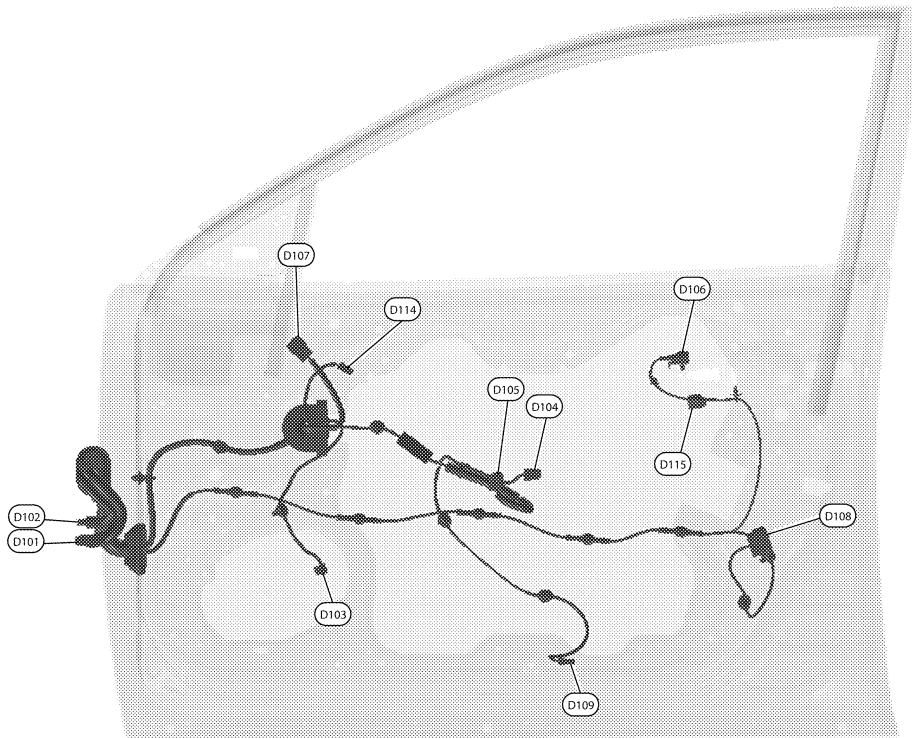

ABMIA0295GB

D101	W/10	: To M14	D107	W/16	: Door mirror RH
D102	W/16	: To M15	D108	GR/6	: Front door lock actuator RH
D103	W/2	: Front door speaker RH	D109	W/2	: Front step lamp RH
D104	W/6	: Front power window motor RH	D114	GR/2	: Front door inside handle illumination RH
D105	W/16	: Power window and door lock/unlock switch RH	D115	B/2	: Front outside handle RH (request switch)
D106	GR/2	: Front outside handle RH (outside key antenna)			

HARNESS

< DTC/CIRCUIT DIAGNOSIS >

REAR DOOR LH HARNESS

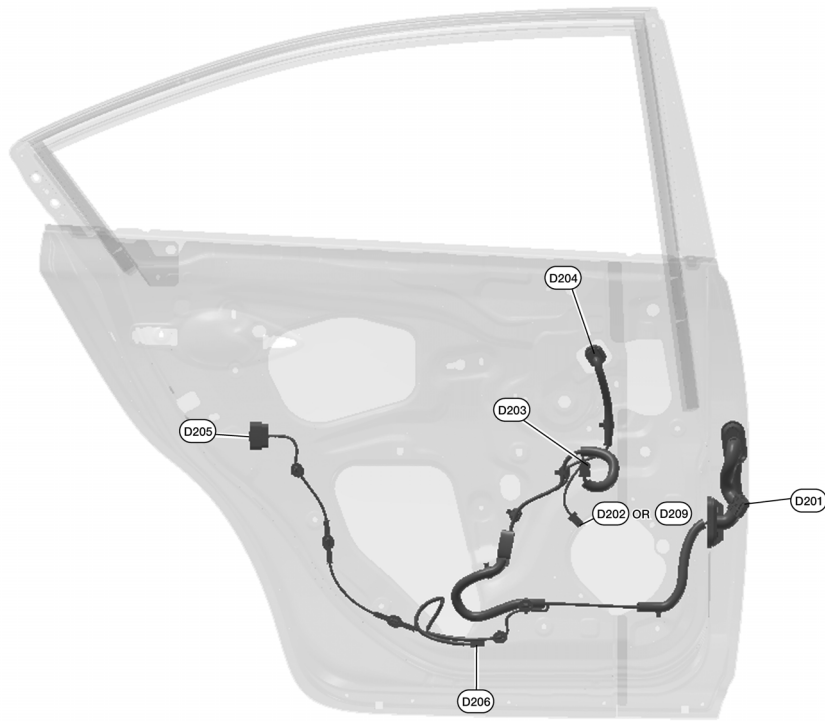

ABMIA3471GB

D201	W/10	: To B6	D205	GR/6	: Rear door lock actuator LH
D202	BR/2	: Rear door speaker LH (except monochrome display without BOSE audio system)	D206	W/2	: Rear step lamp LH
D203	W/8	: Rear power window switch LH	D209	W/2	: Rear door speaker RH (with monochrome display without BOSE audio system)
D204	G/6	: Rear power window motor LH			

A
B
C
D
E
F
G
H
I
J
K
L

PG

HARNESS

< DTC/CIRCUIT DIAGNOSIS >

REAR DOOR RH HARNESS

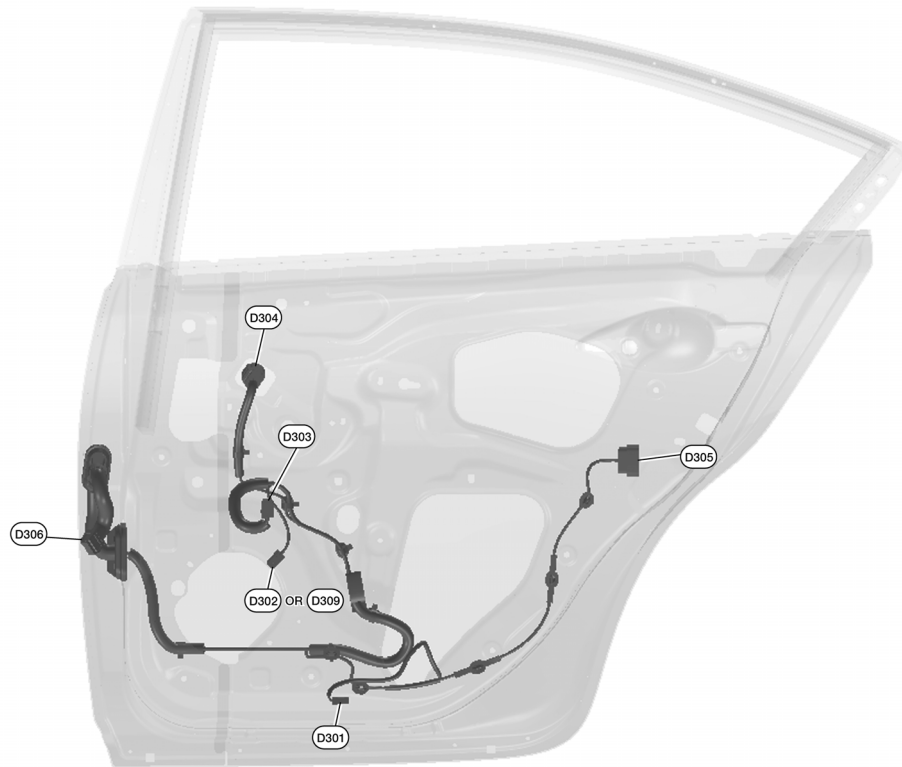

ABMIA3472GB

D301	W/2	: Rear step lamp RH	D305	GR/6	: Rear door lock actuator RH
D302	BR/2	: Rear door speaker RH (except monochrome display without BOSE audio system)	D306	W/10	: To B134
D303	W/8	: Rear power window switch RH	D309	W/2	: Rear door speaker RH (with monochrome display without BOSE audio system)
D304	G/6	: Rear power window motor RH			

ELECTRICAL UNITS LOCATION

< DTC/CIRCUIT DIAGNOSIS >

ELECTRICAL UNITS LOCATION

Electrical Units Location

INFOID:000000009465147

ENGINE COMPARTMENT

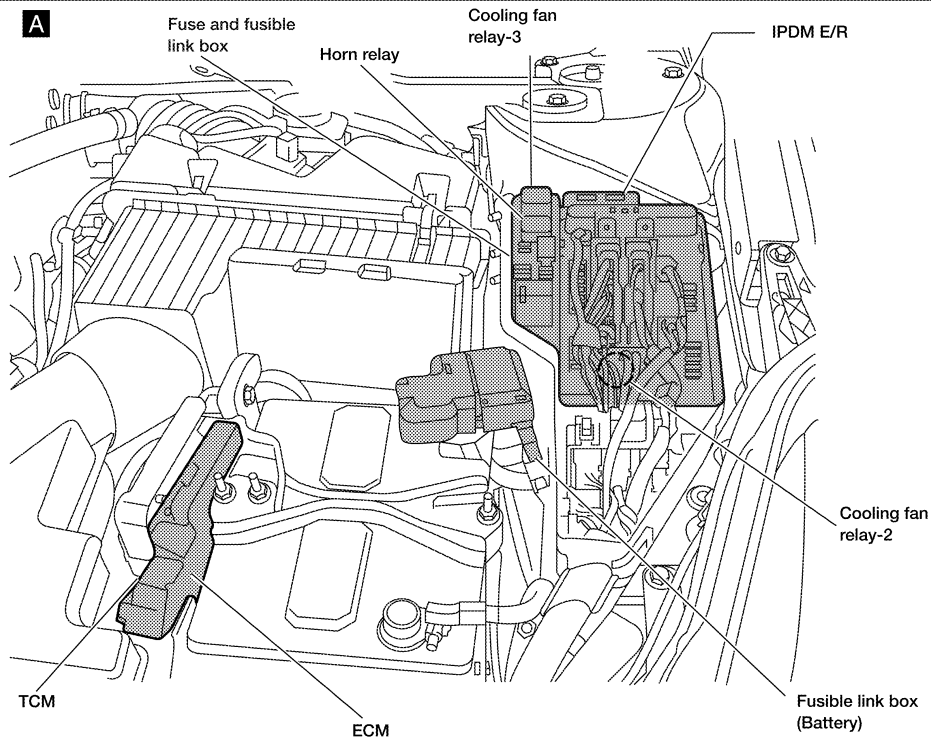
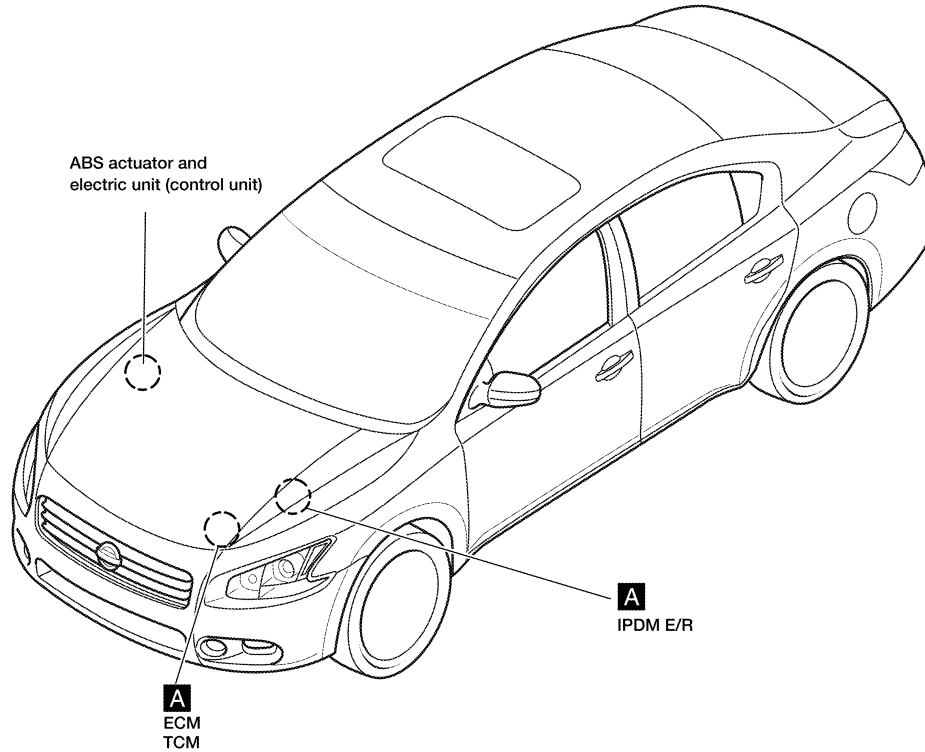

A
B
C
D
E
F
G
H
I
J
K
L
PG
N
O
P

ABMIA1455GB

ELECTRICAL UNITS LOCATION

< DTC/CIRCUIT DIAGNOSIS >

PASSENGER COMPARTMENT

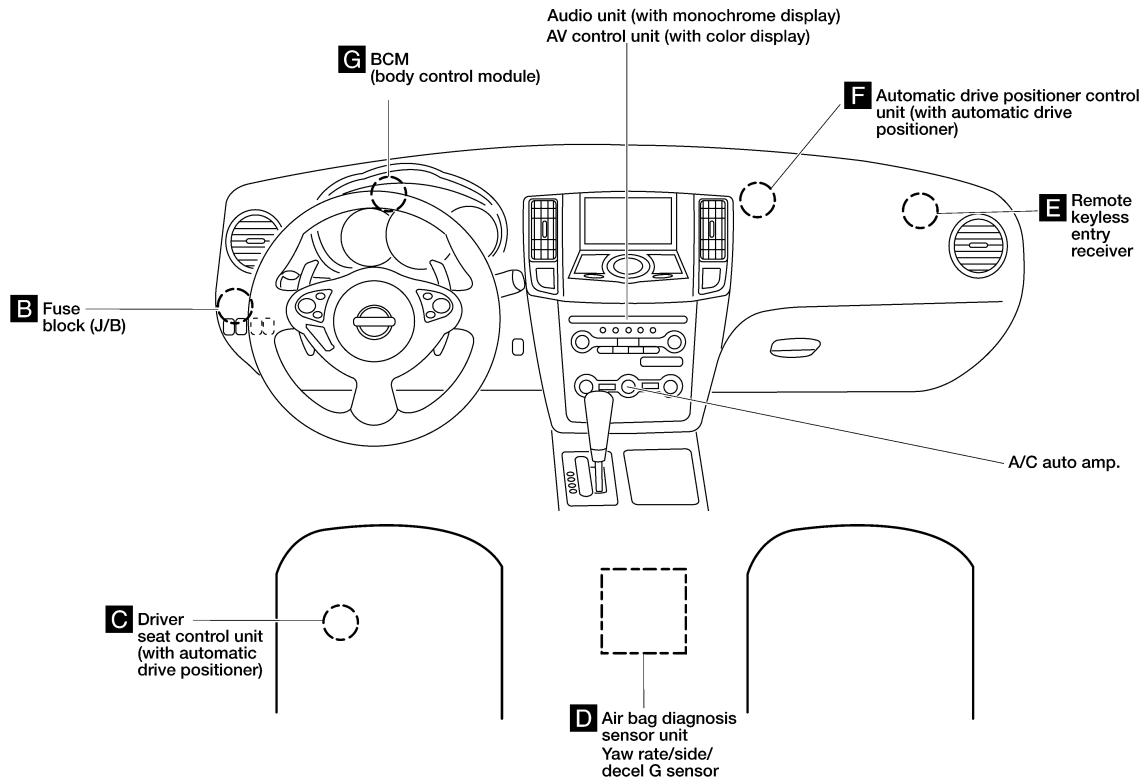

ABMIA4038GB

ELECTRICAL UNITS LOCATION

< DTC/CIRCUIT DIAGNOSIS >

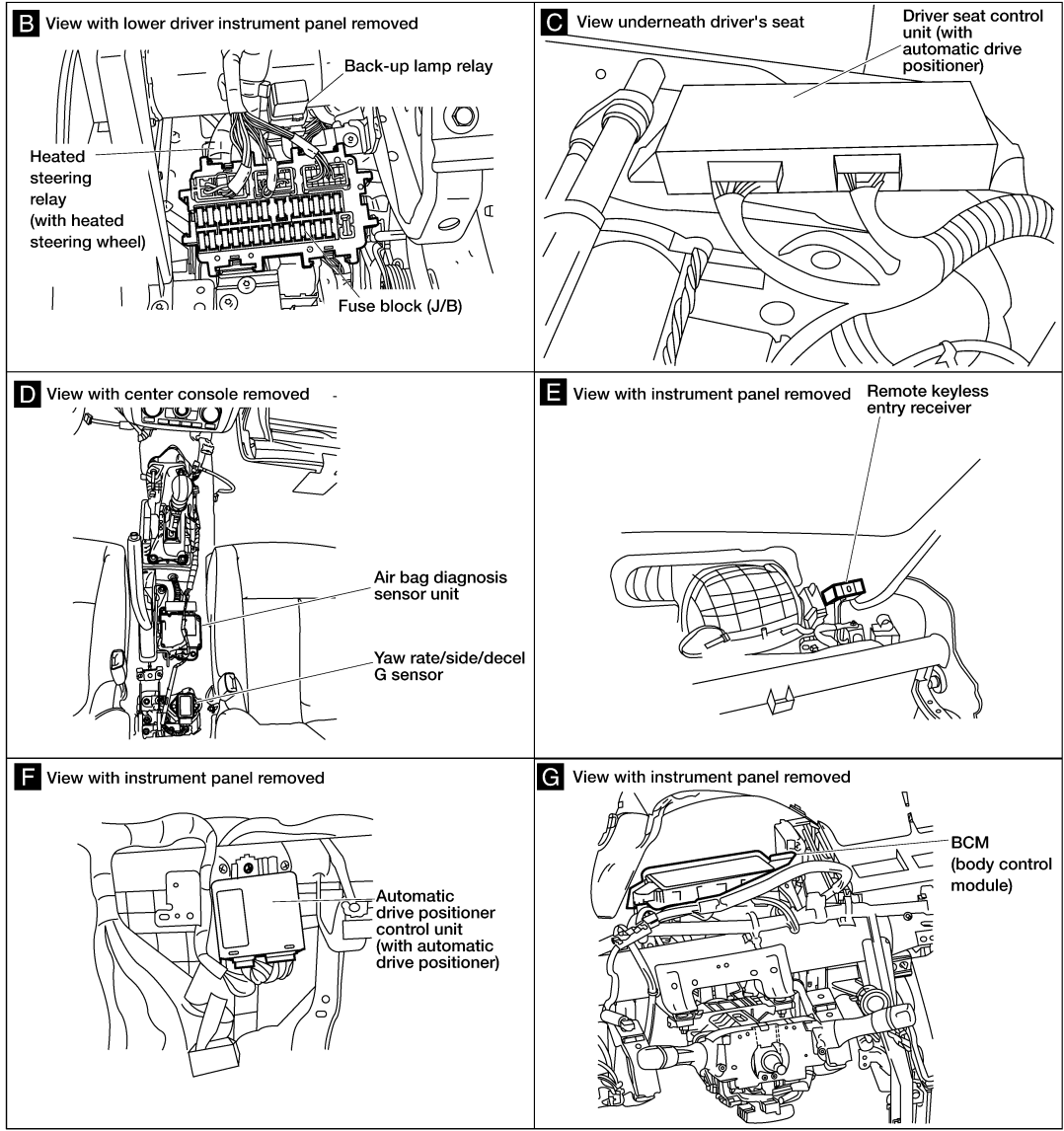

A
B
C
D
E
F
G
H
I
J
K
L

PG

N
O
P

ABMIA2461GB

ELECTRICAL UNITS LOCATION

< DTC/CIRCUIT DIAGNOSIS >

LUGGAGE COMPARTMENT

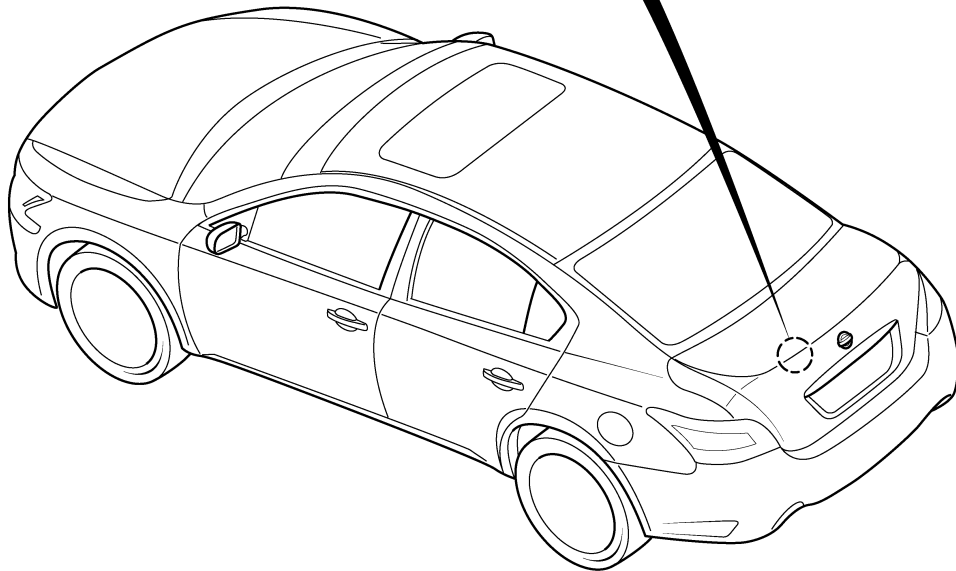
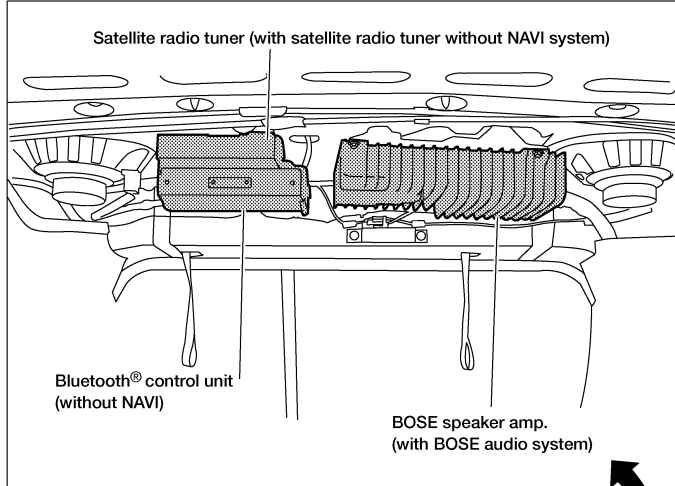

ABMIA5296GB

HARNESS CONNECTOR

< DTC/CIRCUIT DIAGNOSIS >

HARNESS CONNECTOR

Description

INFOID:000000009465148

HARNESS CONNECTOR (TAB-LOCKING TYPE)

- The tab-locking type connectors help prevent accidental looseness or disconnection.
- The tab-locking type connectors are disconnected by pushing or lifting the locking tab(s). Refer to the figure below.

Refer to the next page for description of the slide-locking type connector.

CAUTION:

Do not pull the harness or wires when disconnecting the connector.

[Example]

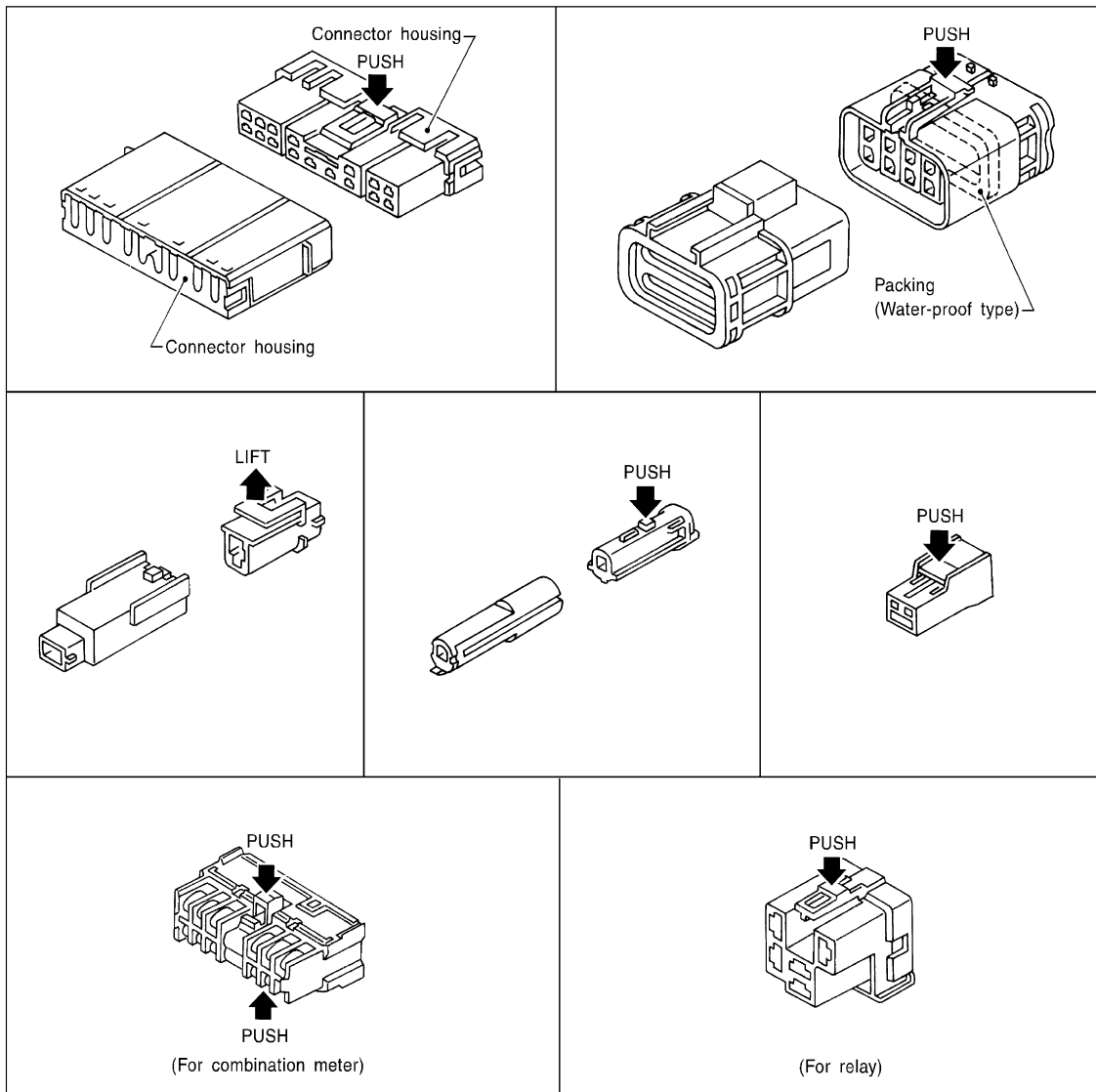

SEL769DA

HARNESS CONNECTOR (SLIDE-LOCKING TYPE)

- A new style slide-locking type connector is used on certain systems and components, especially those related to OBD.
- The slide-locking type connectors help prevent incomplete locking and accidental looseness or disconnection.

A
B
C
D
E
F
G
H
I
J
K
L
PG
N
O
P

HARNESS CONNECTOR

< DTC/CIRCUIT DIAGNOSIS >

- The slide-locking type connectors are disconnected by pushing or pulling the slider. Refer to the figure below.

CAUTION:

- Do not pull the harness or wires when disconnecting the connector.
- Be careful not to damage the connector support bracket when disconnecting the connector.

[Example]

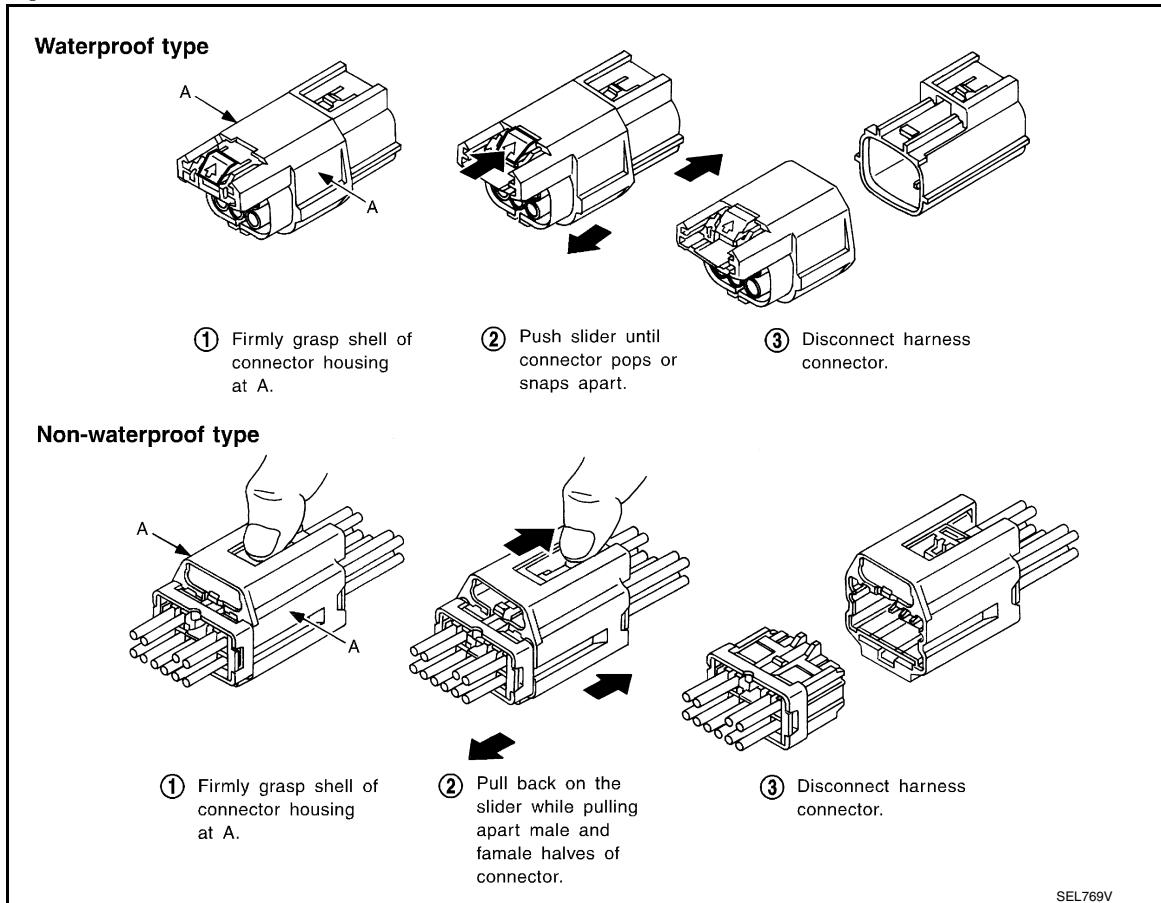

HARNESS CONNECTOR (LEVER LOCKING TYPE)

- Lever locking type harness connectors are used on certain control units and control modules such as ECM, ABS actuator and electric unit (control unit), etc.
- Lever locking type harness connectors are also used on super multiple junction (SMJ) connectors.
- Always confirm the lever is fully locked in place by moving the lever as far as it will go to ensure full connection.

CAUTION:

HARNESS CONNECTOR

< DTC/CIRCUIT DIAGNOSIS >

- Always confirm the lever is fully released (loosened) before attempting to disconnect or connect these connectors to avoid damage to the connector housing or terminals.

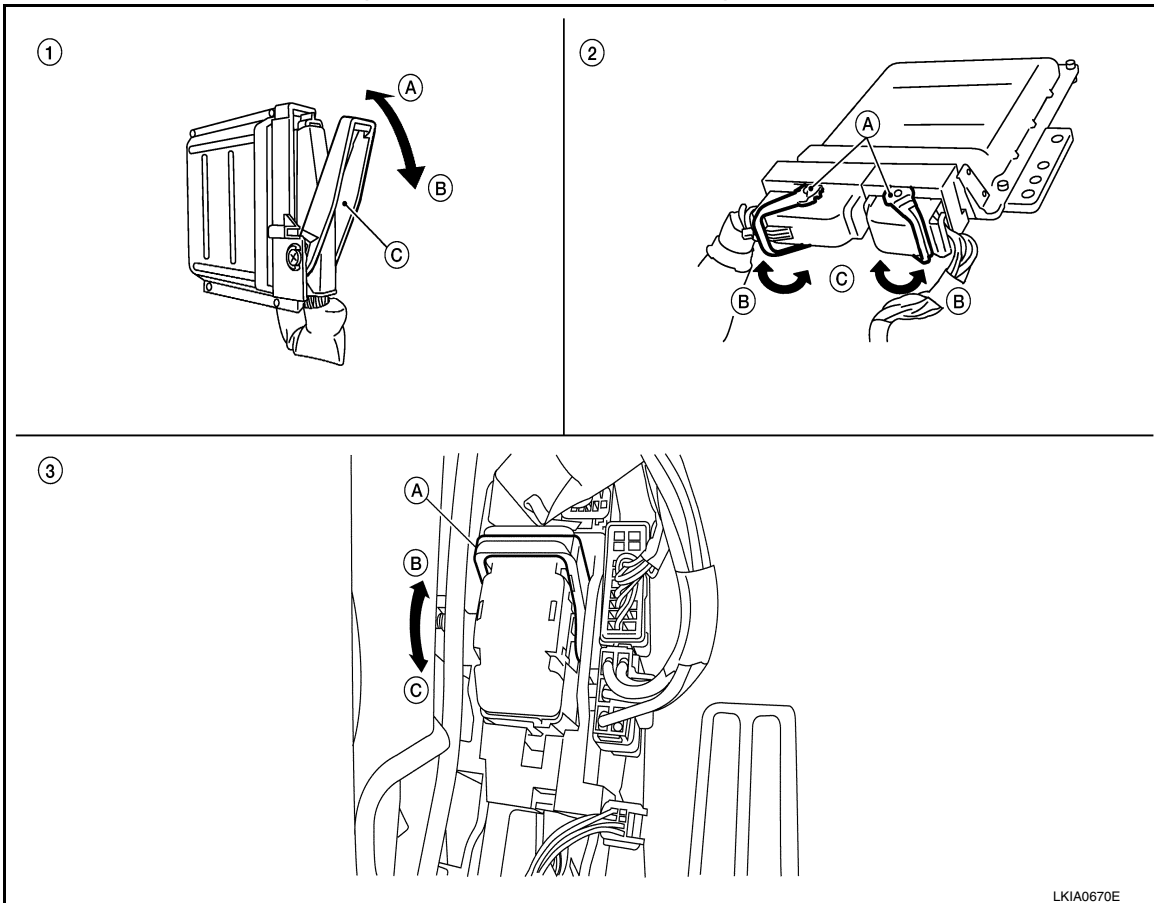

- | | | |
|-----------------------------------|---------------------------------|------------------|
| 1. Control unit with single lever | 2. Control unit with dual lever | 3. SMJ connector |
| A. Fasten | A. Levers | A. Lever |
| B. Loosen | B. Fasten | B. Fasten |
| C. Lever | C. Loosen | C. Loosen |

HARNESS CONNECTOR (DIRECT-CONNECT SRS COMPONENT TYPE)

- SRS direct-connect type harness connectors are used on certain SRS components such as air bag modules and seat belt pre-tensioners.
- Always pull up to release black locking tab prior to removing connector from SRS components.
- Always push down to lock black locking tab after installing connector to SRS components. When locked, the black locking tab is level with the connector housing.

CAUTION:

- Do not pull the harness or wires when removing connectors from SRS components.

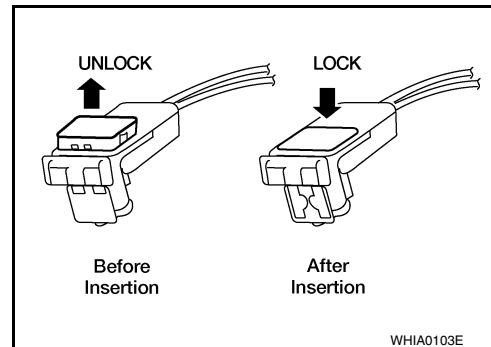

WHIA0103E

STANDARDIZED RELAY

< DTC/CIRCUIT DIAGNOSIS >

STANDARDIZED RELAY

Description

INFOID:000000009465149

NORMAL OPEN, NORMAL CLOSED AND MIXED TYPE RELAYS

Relays can mainly be divided into three types: normal open, normal closed and mixed type relays.

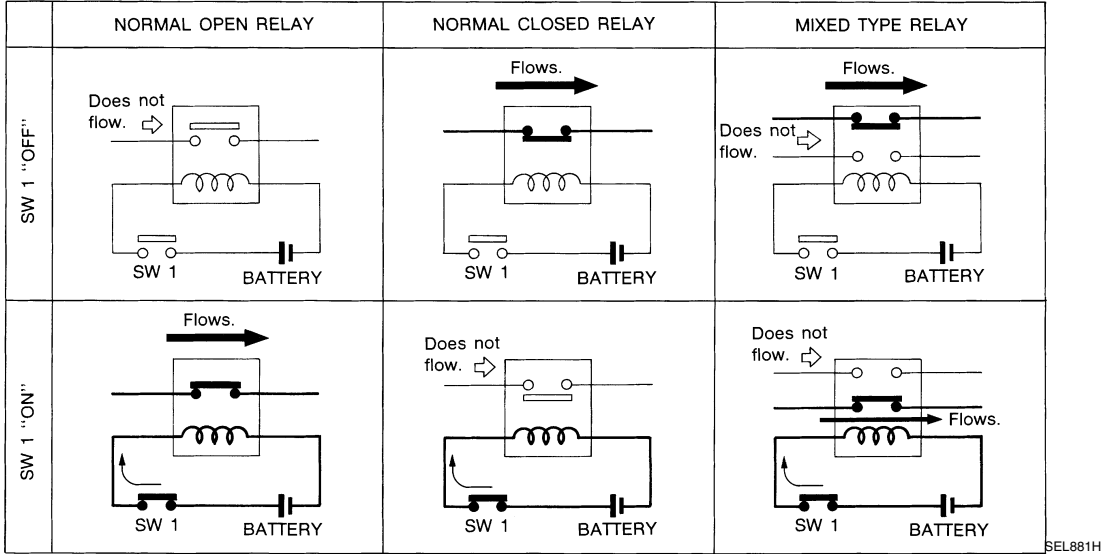

SEL881H

TYPE OF STANDARDIZED RELAYS

- 1M 1 Make
- 2M 2 Make
- 1T 1 Transfer
- 1M·1B 1 Make 1 Break

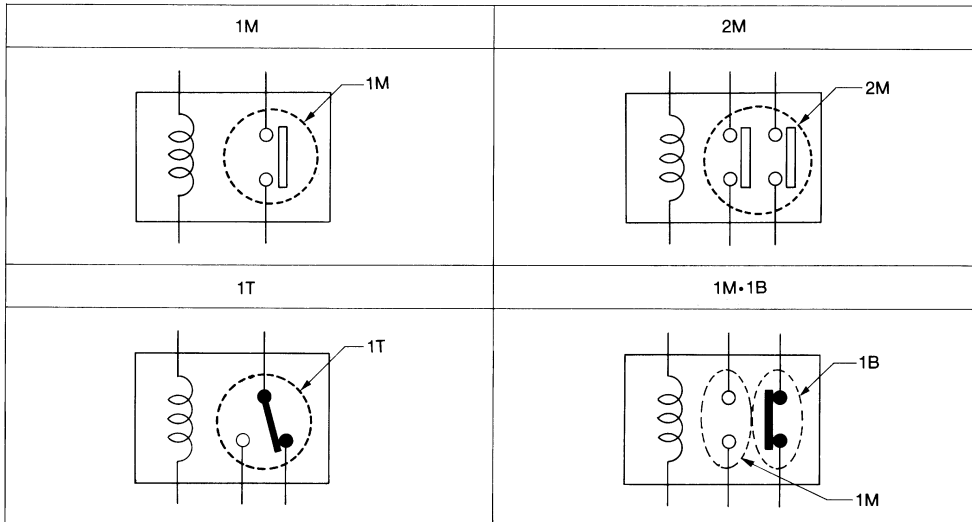

SEL882H

STANDARDIZED RELAY

< DTC/CIRCUIT DIAGNOSIS >

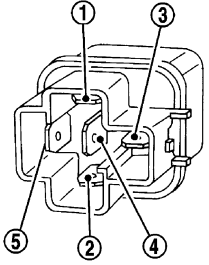
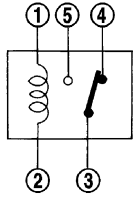
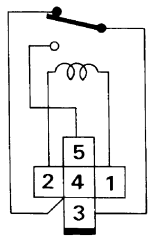
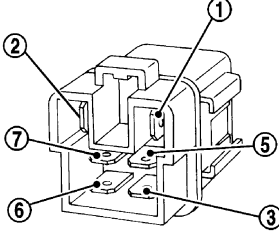
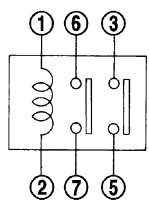
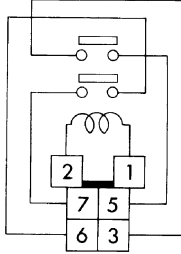
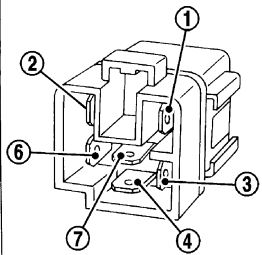
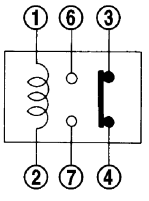
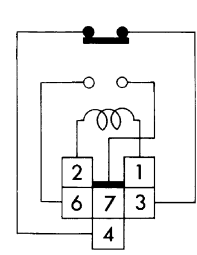
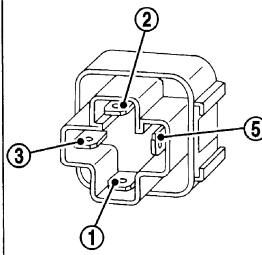
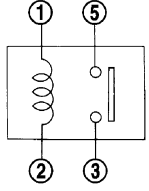
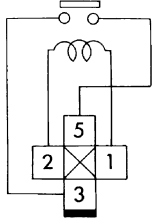
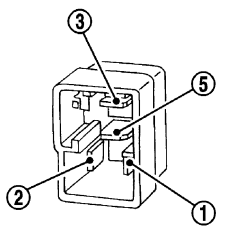
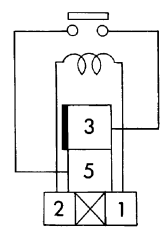
Type	Outer view	Circuit	Connector symbol and connection	Case color
1T				BLACK
2M				BROWN
1M•1B				GRAY
1M				BLUE
				

The arrangement of terminal numbers on the actual relays may differ from those shown above.

SEL188W

A
B
C
D
E
F
G
H
I
J
K
L
PG
N
O
P

FUSE BLOCK - JUNCTION BOX (J/B)

< DTC/CIRCUIT DIAGNOSIS >

FUSE BLOCK - JUNCTION BOX (J/B)

Terminal Arrangement

INFOID:000000009465150

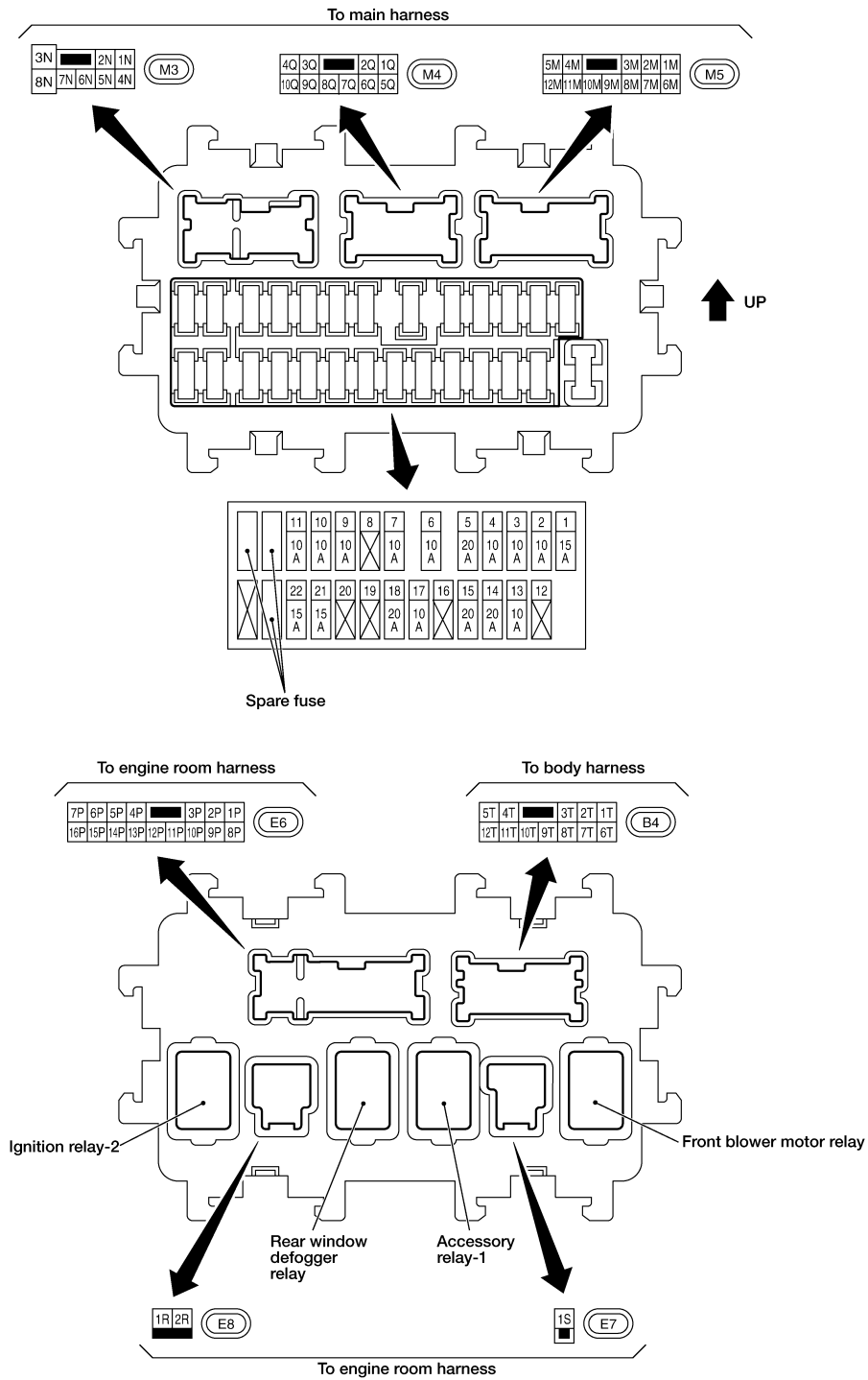

ABMIA4030GB

FUSE, FUSIBLE LINK AND RELAY BOX

< DTC/CIRCUIT DIAGNOSIS >

FUSE, FUSIBLE LINK AND RELAY BOX

Terminal Arrangement

INFOID:000000009465151

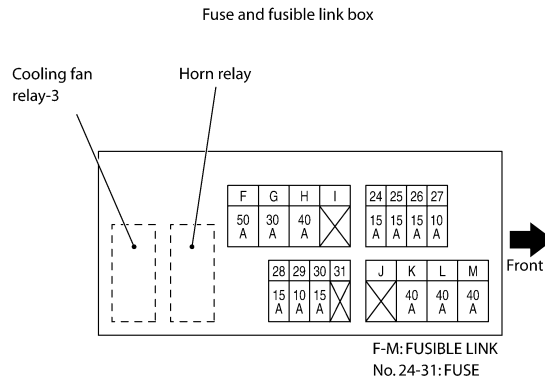
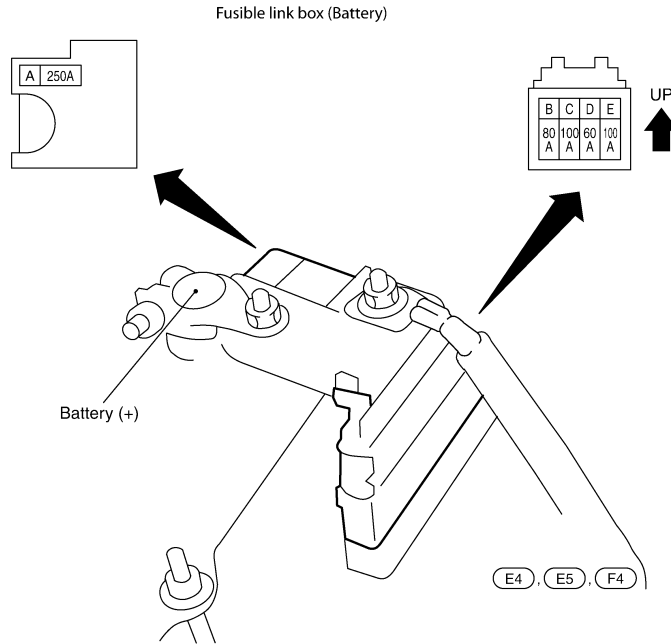

ABMIA0307GB

A
B
C
D
E
F
G
H
I
J
K
L
PG
N
O
P

IPDM E/R (INTELLIGENT POWER DISTRIBUTION MODULE ENGINE ROOM)

< DTC/CIRCUIT DIAGNOSIS >

IPDM E/R (INTELLIGENT POWER DISTRIBUTION MODULE ENGINE ROOM)

Fuse, Connector and Terminal Arrangement

INFOID:00000009465152

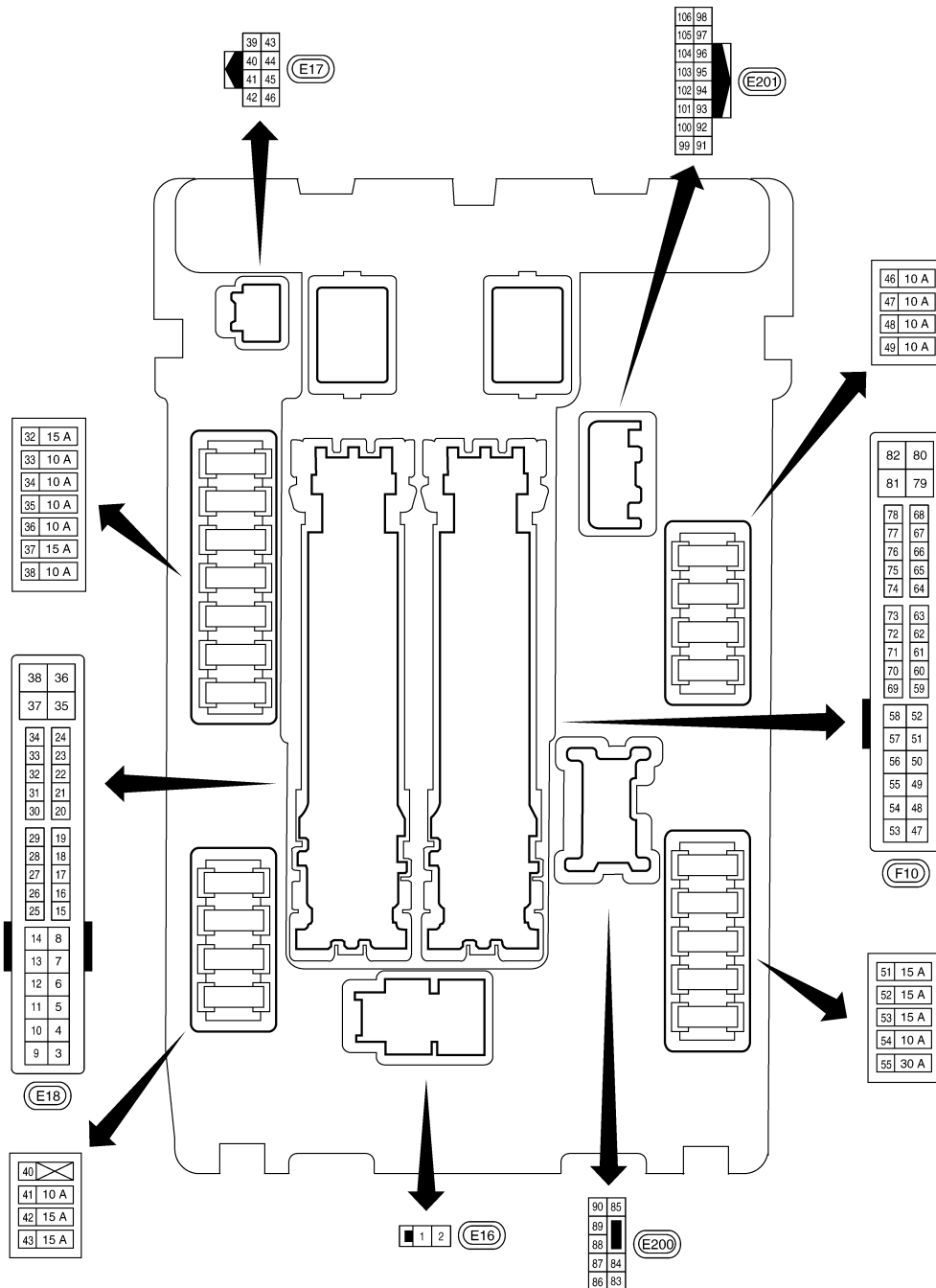

ABMIA4039GB

PRECAUTIONS

< PRECAUTION >

PRECAUTION

PRECAUTIONS

Precaution for Supplemental Restraint System (SRS) "AIR BAG" and "SEAT BELT PRE-TENSIONER"

INFOID:000000009465153

The Supplemental Restraint System such as "AIR BAG" and "SEAT BELT PRE-TENSIONER", used along with a front seat belt, helps to reduce the risk or severity of injury to the driver and front passenger for certain types of collision. This system includes seat belt switch inputs and dual stage front air bag modules. The SRS system uses the seat belt switches to determine the front air bag deployment, and may only deploy one front air bag, depending on the severity of a collision and whether the front occupants are belted or unbelted. Information necessary to service the system safely is included in the SR and SB section of this Service Manual.

WARNING:

- To avoid rendering the SRS inoperative, which could increase the risk of personal injury or death in the event of a collision which would result in air bag inflation, all maintenance must be performed by an authorized NISSAN/INFINITI dealer.
- Improper maintenance, including incorrect removal and installation of the SRS, can lead to personal injury caused by unintentional activation of the system. For removal of Spiral Cable and Air Bag Module, see the SR section.
- Do not use electrical test equipment on any circuit related to the SRS unless instructed to in this Service Manual. SRS wiring harnesses can be identified by yellow and/or orange harnesses or harness connectors.

PRECAUTIONS WHEN USING POWER TOOLS (AIR OR ELECTRIC) AND HAMMERS

WARNING:

- When working near the Airbag Diagnosis Sensor Unit or other Airbag System sensors with the Ignition ON or engine running, DO NOT use air or electric power tools or strike near the sensor(s) with a hammer. Heavy vibration could activate the sensor(s) and deploy the air bag(s), possibly causing serious injury.
- When using air or electric power tools or hammers, always switch the Ignition OFF, disconnect the battery, and wait at least 3 minutes before performing any service.

A
B
C
D
E
F
G
H
I
J
K
L
PG
N
O
P

PREPARATION

< PREPARATION >

PREPARATION

PREPARATION

Special Service Tool

INFOID:000000009465154

The actual shapes of the tools may differ from those illustrated here.

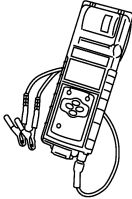
Tool number (TechMate No.) Tool name	Description
<p>— (—) Model GR8-1200 NI Multitasking battery and electrical diagnostic station</p>  <p style="text-align: right;">AWI1A1239ZZ</p>	<p>Tests batteries, starting and charging systems and charges batteries. For operating instructions, refer to diagnostic station instruction manual.</p>
<p>— (—) Model EXP-800 NI Battery and electrical diagnostic analyzer</p>  <p style="text-align: right;">JSMIA0806ZZ</p>	<p>Tests batteries and charging systems. For operating instructions, refer to diagnostic analyzer instruction manual.</p>

Commercial Service Tool

INFOID:000000009465155

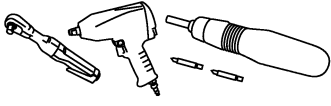
Tool name	Description
<p>Power tool</p>  <p style="text-align: right;">PIIB1407E</p>	<p>Loosening nuts, screws and bolts</p>

BATTERY

< REMOVAL AND INSTALLATION >

REMOVAL AND INSTALLATION

BATTERY

Exploded View

INFOID:000000009465156

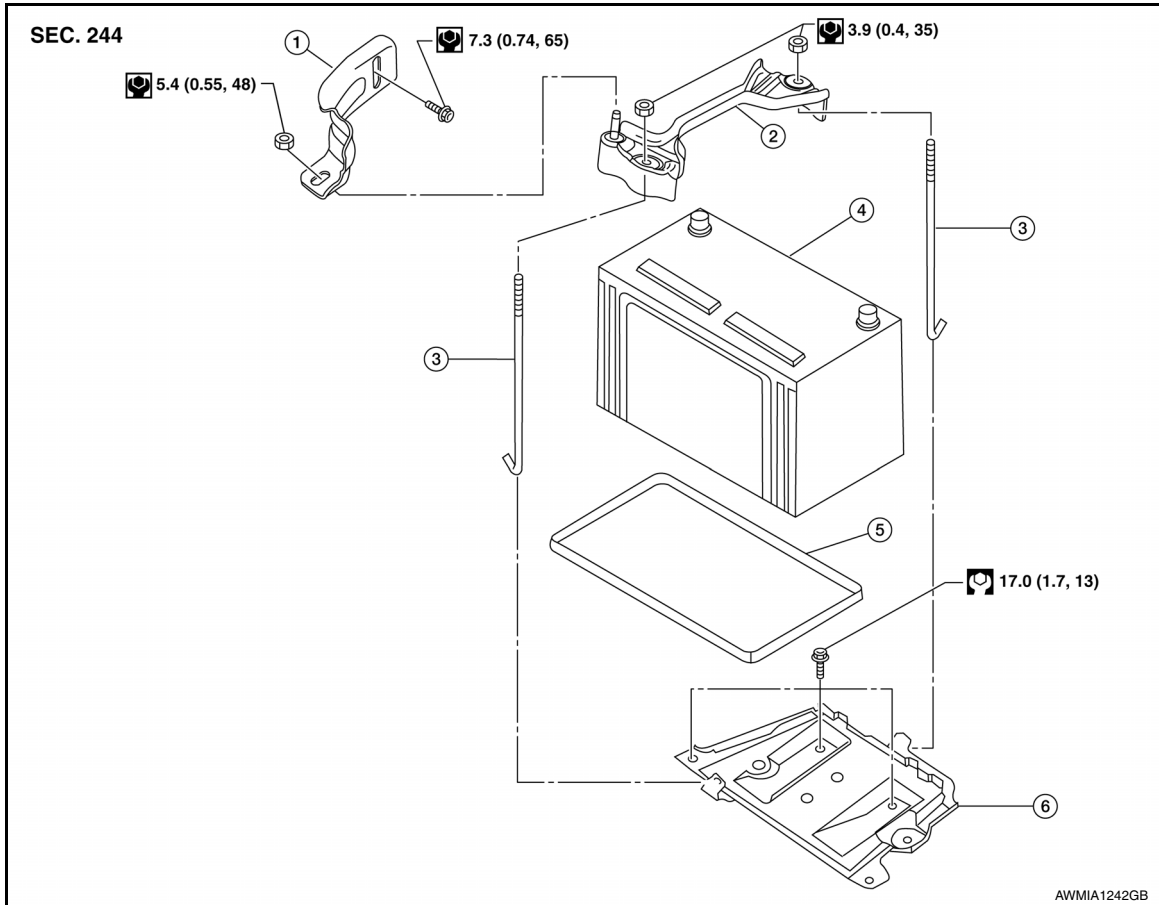

- | | | |
|----------------------|-----------------------|-----------------|
| 1. Upper ECM bracket | 2. Battery frame | 3. Battery rods |
| 4. Battery | 5. Battery tray liner | 6. Battery tray |

Removal and Installation (Battery)

INFOID:000000009465157

REMOVAL

- Loosen battery cable assembly nuts, and disconnect both battery terminals.
CAUTION:
When disconnecting, disconnect the negative terminal first.
- Remove upper ECM bracket nut and bolt and ECM upper bracket.
- Remove battery rod nuts and battery frame.
- Remove battery.

INSTALLATION

Installation is in the reverse order of removal.

Battery cable assembly nut : 5.4 N·m (0.55 kg-m, 48 in-lb)

CAUTION:

When connecting, connect the positive terminal first.

Reset electronic systems as necessary. Refer to [PG-5, "ADDITIONAL SERVICE WHEN REMOVING BATTERY NEGATIVE TERMINAL : Special Repair Requirement"](#).

A
B
C
D
E
F
G
H
I
J
K
L

PG

N
O
P

BATTERY

< REMOVAL AND INSTALLATION >

Removal and Installation (Battery Tray)

INFOID:000000009465158

REMOVAL

1. Remove battery and battery tray liner. Refer to [PG-67, "Removal and Installation \(Battery\)"](#).
2. Remove air cleaner assembly. Refer to [EM-24, "Removal and Installation"](#).
3. Remove ECM.
4. Disconnect transmission control module (TCM). Refer to [TM-168, "Removal and Installation"](#).
5. Remove the lower ECM bracket.
6. Remove current sensor from battery tray.
7. Remove the battery tray bolts and battery tray.

INSTALLATION

Installation is in the reverse order of removal.

Reset electronic systems as necessary. Refer to [PG-5, "ADDITIONAL SERVICE WHEN REMOVING BATTERY NEGATIVE TERMINAL : Special Repair Requirement"](#). [PG-67, "Removal and Installation \(Battery\)"](#)

BATTERY

< SERVICE DATA AND SPECIFICATIONS (SDS)

SERVICE DATA AND SPECIFICATIONS (SDS)

BATTERY

Battery

INFOID:000000009465159

Type*	GR35
Capacity (20HR) minimum V-AH	12-60
Cold cranking current A (For reference value)	550

*: Always check with the Parts Department for the latest parts information.

A
B
C
D
E
F
G
H
I
J
K
L
PG
N
O
P